

Tools & Equipment

QUARTER ONE 2022

January, February & March

**EASY WELD 140 FC-I
FLUX-CORE WELDER
#261**

\$299

- Gasless / Flux-Core Welding Only
- 120 Volts Input / 140 Amps Output
- Welds Up to 1/4"
- Uses .030" FC Wire
- Inverter Power Source
- 8' MIG Gun, 8' Ground Cable & Clamp, 6' Power Cable
- 1-Year Warranty
- Weight: 19 lbs



Forney

**HEAVY DUTY
TORCH OUTFIT
#1710**

\$299

- Cuts 3 / 4" (up to 8") with proper tips & Welds 1/2"
- Ideal for auto repair, general fabrication, maintenance cutting, brazing heating, DIY
- Includes: oxygen regulator, acetylene regulator, torch handle, cutting attachment, goggles



**TECHRITEPRO
BUNDLE TOOL KITS
#WRTTRP100-RS12**

\$489

- Includes tool, OBDII cable, power supply, quick start guide & rubber stem Rite-Sensors®
- RITE-SENSOR® RITE-SYNC® Process Enabled + extended OBDII Coverage
- High resolution 2.8" display with Bluetooth
- One-Year Software & Warranty



**Includes 12
Rite-Sensors®
Value: \$474**

**BARTEC
USA
TPMS PROFESSIONALS**

**M18™ FUEL 1"
D-HANDLE - BARE TOOL
#2869-20**

\$799

- 4-Mode drive control + bolt removal mode provides more control
- Highly compact cordless high-torque 1/2"
- Powerstate™ brushless motor delivers up to 1000 ft. / lbs. of fastening torque



Milwaukee

**M18™ FUEL 1" D-HANDLE
KIT + 2 12.0 AH BATTERIES
#2869-22HD**

\$1,299

**FINANCE:
\$34.45 / month for
60 months**

- Remove and install up to 120 lug nuts on a single HIGH OUTPUT™ HD12.0Ah battery
- Delivers up to 2,000 ft-lbs of torque
- Built-In Light



**MAXISYS MS906PRO-TS
DIAGNOSTIC TABLET
#MS906PROTS**

\$2,099

**FINANCE:
\$55.67 / month for
60 months**

- Compatible with US, Asian & European vehicles, 1996+
- Complete TPMS servicing
- 8" Wireless touchscreen tablet with antenna, Bluetooth-enabled MaxiSYS VCI200
- Bi-directional control capability + Active test
- Performs coding & adaptations



AUTEL

NetworkToolCat.com

Offers good through 03.31.22

Fast. Flexible. Financing.

FOR THE AUTOMOTIVE INDUSTRY.

INTRODUCING FINANCE OPTIONS FROM GREATAMERICA

The Pronto Network has partnered with GreatAmerica Financial Services to help you provide equipment finance solutions to your wholesale customers.

▶ SIMPLE PROCESS

Instant quotes, an online application, quick credit decisions, and no fuss documentation.

▶ FLEXIBLE TERMS

Your customer chooses the term that fits their budget and we'll take care of the rest.

▶ COMPLETE COVERAGE

Our finance programs allow your customer to combine the entire equipment purchase (including tax, install, and freight) into one low monthly payment.



HARD WORK • INTEGRITY • EXCELLENCE



Call us today!

800-487-3636

GREATAMERICA.COM

index

| | | | |
|--|------------------|-------------------------------------|-----------------------|
| AIR COMPRESSORS | 54-57 | JUMP STARTERS | 35 |
| AIR CONDITIONING | 24-26 | LIGHTING | 65, 73-75 |
| AIR TOOLS & ACCESSORIES ... | 58-59 | OIL SERVICE | 40-41, 49--50 |
| AUTOMOTIVE LIFTS | 4-7 | PARTS/PRESSURE WASHERS | 38 |
| AUTO DETAILING | 82-83 | POWER TOOLS | 59, 64-65 |
| BATTERY SERVICE | 33-36 | PULLERS & SOCKETS | 58, 62, 69, 71 |
| BODY REPAIR | 15 | SAFETY EQUIPMENT | 79-80 |
| BRAKE SERVICE | 23 | SHOP EQUIPMENT | 37-44 |
| DIAGNOSTICS | 27-32 | SHOP PRESSES | 44 |
| DRILL BITS & BLADES | 62, 64-66 | SHOP SUPPLIES | 76-81 |
| ENGINE STANDS | 19 | SPECIALTY TOOLS | 68-72 |
| FANS | 37 | TOOL STORAGE | 60-61 |
| FLUID/FUEL HANDLING | 48-53 | TIRE SERVICE | 8-16 |
| GENERATORS | 39-40 | TPMS SERVICE | 13--15 |
| HAND CLEANER | 78 | WASTE OIL HEATERS | 41 |
| HAND TOOLS | 70-71 | WELDING | 45-47 |
| HEADLIGHT ALIGNMENT | 42 | WRENCHES | 70 |
| JACKS & HYDRAULICS | 17-22 | | |

Prices & specifications are subject to change without notice or liability. Prices do not include vehicles, installation freight or optional equipment unless specified. Customers are responsible for off-loading equipment upon arrival. Ask your sales rep for details.

WARNING: These products can expose you to certain chemicals, which is known to the State of California to cause cancer.

For more information, go to www.P65Warnings.ca.gov.

automotive lifts



Training & installation not included



Training & installation not included



Training & installation not included

10,000 LB. 2-POST LIFT #F10

\$3,999

FINANCE:
\$106.05 / month for 60 months

- 3-stage front arms to accommodate a wide range of vehicles
- Direct pull cylinders minimize wear
- Round adapters & extensions
- 12 months parts & labor warranty



10,000 LB. 2-POST LIFT #I10

\$4,199

FINANCE:
\$111.36 / month for 60 months

- SPOT RITE ARMS position behind the column for easy spotting
- Direct pull cylinders minimize wear
- Round adapters & extensions
- 12 months parts & labor warranty



Training & installation not included

12,000 LB. 2-POST LIFT #I12

\$7,499

FINANCE:
\$174.13 / month for 60 months

- 3-stage arms to pick up a wide range of cars & trucks
- Truck adapters & extensions
- Available in 143", 154", 166" & 178" heights
- 12 months parts & labor warranty



Training & installation not included



Vehicle, Training and Installation not included



Training & Installation not included



Vehicle, Training & Installation not included

10,000 LB. 2-POST LIFT #XPR-10S

\$5,099

FINANCE:
\$118.40 / month for 60 months

- Turned Column, (145" Hgt / +1" Ceiling)
- 3-Stage Front Arms
- Screw-Up Pads (4.1/4" low hgt)
- Adjustable Width
- Includes 2.1/2" Stack Adapters (4)

Training & installation not included



10,000 LB. 2-POST SYMMETRIC LIFT #XPR-10AS

\$5,159

FINANCE:
\$119.79 / month for 60 months

- 145" Hgt / +1" Ceiling
- 3-Stage Front Arms
- Screw-Up Pads (4.1/4" low hgt)
- Adjustable Width
- Includes 2.1/2" Stack Adapters (4)

Training & installation not included



12,000 LB. 2-POST SYMMETRIC LIFT #XPR-12CL

\$8,619

FINANCE:
\$200.13 / month for 60 months

- Height: 170" + 1" ceiling
- 3-Stage front arms & rear arms
- Drop-in pads (5" low height)
- Includes 2.5" & 5" stack adapters (4 each) & frame cradles (4)

Training & installation not included





Vehicle, Training & Installation not included



SPOA10 shown

Vehicle, Training & Installation not included



RA & TA Adapters shown

Vehicle, Training & Installation not included

10,000 LB. 2-POST LIFT #SPO10 SYMMETRIC

\$5,299

FINANCE: \$123.04 / month for 60 months

- Made in Madison, IN
- 3 Position Flip-Up Adapters
- Red, Blue or Black & 12' Minimum Ceiling Height
- Additional Height Options Available



10,000 LB. 2-POST LIFT #SPOA10 ASYMMETRIC

\$5,299

FINANCE: \$123.04 / month for 60 months

- Made in Madison, IN
- 3 Position Flip-Up Adapters
- Red, Blue or Black
- 12' Minimum Ceiling Height
- Additional Height Options Available



ROTARY TRIO ARM™ #SPOA10RA/TA/FA

\$5,869

FINANCE: \$136.28 / month for 60 months

- Improve Technician Productivity
- Two-Piece Three-Stage Arms to Accommodate More Vehicles
- Adjustable Adapters to Spot Vehicle Correctly the First Time
- Available with 3 Adapter Options: Round Adapters, Truck Adapters or Flip-Up Adapters



10,000 LB 2-POST LIFT FLIP-UP ADAPTER 2' EXTENSION #SPO10 EH2 & #SPOA10 EH2

- True symmetrical, single-piece • Standard front & rear three-stage arms • Truck adapters with stackable inserts • Additional Height Options



Training & installation not included

\$5,999

FINANCE: \$139.30 / month for 60 months



Vehicle, Training & Installation not included

12,000 LB. 3-STAGE ARMS 2-POST LIFT #SPO12-TA

\$8,299

FINANCE: \$192.70 / month for 60 months

- Made in Madison, IN
- Rectangular truck adapters & extensions
- 73.75" Rise & 13'9" Minimum ceiling height
- Additional height options available



12,000 LB. 2-POST LIFT 1-FOOT EXTENSION #SPO12TAEH1

\$8,979

FINANCE: \$208.49 / month for 60 months

12,000 LB. 2-POST LIFT 2-FOOT EXTENSION #SPO12TAEH2

\$9,229

FINANCE: \$214.30 / month for 60 months



Vehicle, Training & Installation not included

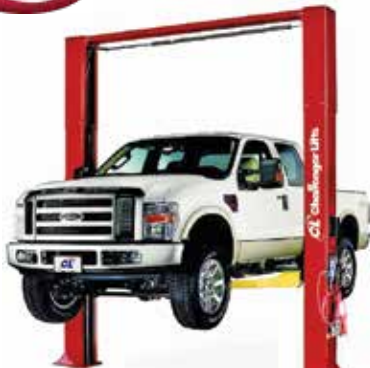

Vehicle, Training & Installation not included



Vehicle, Training & Installation not included



Vehicle, Training & Installation not included

VERSYMMETRIC® 2-POST LIFT #CL10V3

\$6,939

FINANCE: \$161.12 / month for 60 months

- Conventional Power Controls
- DIRECTSPOT™ offset 3-stage front & rear arms & single-point mechanical lock release



SYMMETRIC 2-POST LIFT #CL12

\$10,539

FINANCE: \$239.24 / month for 60 months

- 3-stage front and rear arms
- Mechanical lock release (164" H)



HEAVY DUTY MOBILE COLUMN LIFTS (SET OF 4) #CLHM-140-4

\$50,209

FINANCE: \$1,067.44 / month for 60 months

- 14,000lbs Capacity
- Battery Powered
- Wireless, adjustable carriage



4-POST LIFTS



Vehicle, Training and Installation not Included



Training & Installation not Included



Training & Installation not Included



Vehicle, Training & Installation not included

9,000 LB. 4-POST CLOSED LIFT #HD-9XL

\$5,159

FINANCE: \$119.79 / month for 60 months

- 177" Wheelbase / 224" Overall Length / 19" Wide Runways



BendPak

14,000 LB. 4-POST CLOSED LIFT #CR14

\$6,199

FINANCE: \$143.94 / month for 60 months

- Single piece, 20" wide, steel runways
- Airline included
- Powder coated to resist rust
- Up to 182" wheel base



FORWARDLIFT

14,000 LB. 4-POST CLOSED LIFT #SM14

\$6,489

FINANCE: \$150.67 / month for 60 months

- Single-Piece, 20" Wide Steel Runways
- Filter/Regulator/Lubricator Included
- Powder Coated to Resist Rust
- Up to 182" Wheel Base



Rotary

14,000 LB. 4-POST CLOSED LIFT #HDS-14X

\$7,669

FINANCE: \$178.07 / month for 60 months

- 225" Wheelbase / 271" Overall Length / 20" Wide Runways



BendPak



Vehicle, Training & Installation not included



Vehicle, Training & Installation not included



Vehicle, Training & Installation not included



Vehicle, Training & Installation not included

14,000 LB. 4-POST LIFT #SMO14

\$8,439

FINANCE: \$195.95 / month for 60 months

- Open Front for Easier Technician Access
- Single-Piece, 20" Wide Steel Runways
- Filter/Regulator/ Lubricator Included
- Powder Coated to Resist Rust
- Up to 182" Wheel Base



Rotary

9,000 LB. 4-POST DOUBLE-WIDE CLOSED LIFT #HD-9SWX

\$10,589

FINANCE: \$240.37 / month for 60 months

- 177" Wheelbase / 224" Overall Length / 19" Wide Runways
- 82" Rise



BendPak

CLOSED FLAT DECK 4-POST #4115EFX

\$12,349

FINANCE: \$280.32 / month for 60 months

- 22" wide runways
- 247.625" overall extended length



Challenger Lifts

CLOSED FLAT DECK 4-POST #4115XFX

\$12,599

FINANCE: \$286.00 / month for 60 months

- 22" wide runways
- 275.5" overall extended length



Vehicle, Training & Installation not included



Training & Installation not Included



Vehicle, Training & Installation not Included



Vehicle, Training & Installation not included

14,000 LB. 4-POST ALIGNMENT CLOSED LIFT #HDS-14LSXE-PKG

\$14,429

FINANCE: \$327.54 / month for 60 months

- 212" Max 2W Align, 271" overall length, 20" wide runways
- 2 - 7K jacks, turntables & air line kit



BendPak

14,000 LB 4-POST GENERAL LIFT #CRA14

\$14,999

FINANCE: \$340.48 / month for 60 months

- Two lengths configured for vehicles with longer wheelbases
- Oversized slip plates and adjustable radius gauge pockets
- Heavy duty capacity to handle vehicles with wheelbases up to 215"



FORWARDLIFT

14,000 4-POST ALIGNMENT 182" WB #ARO14

\$24,499

FINANCE: \$556.13 / month for 60 months

- Open front four post
- Two 7,000 lbs. rolling jacks
- Two turning radius gauges



Rotary

OPEN-FRONT ALIGNMENT RACK PACKAGE #AR4115XA0

\$32,909

FINANCE: \$716.10 / month for 60 months

- 142" overall width with 22" wide runways
- 277.75" overall XL extended length
- Includes (2) RJ7.5 rolling jacks, internal air line kit, flush mount stainless steel turn plates, rear slip plates, turn plate bridges, work-steps and automatic wheel stops



Challenger Lifts



Training & installation not included



Training & installation not included



Training & installation not included

15K 4-POST ALIGNMENT LIFT + EXTENDED LEG #EELR708APKG

\$35,199

FINANCE: \$765.93 / month for 60 months

- 120" drive-on clearance / 125" body clearance allows dual-wheel trucks to drive on without interference
- Best-in-class, ultra-wide, 26" runways accommodate wide-track vehicles
- Open-front construction provides easy access to service areas for hassle-free adjustments and repairs
- Imaging alignment compatible – easily accommodate split-roll during alignment using AC200 or AC400 clamps



Freight Included

14K SCISSOR ALIGNMENT LIFT + STANDARD LIGHTS & LOCKING KIT #EELR789APKG

\$38,849

FINANCE: \$845.35 / month for 60 months

- Maintenance reduced rear slip plates use oversized, encapsulated bearings that roll upward to protect against environment debris
- Four hydraulic cylinders in a cross aligned arrangement provide secure lifting power and added safety
- Approach ramps are equipped with end sliders to minimize noise and reduce floor damage



Freight Included

14K SCISSOR CAR ALIGNMENT LIFT #SX14

\$38,619

FINANCE: \$840.35 / month for 60 months

- 14K Capacity, Single Scissor with 25.5" Runway width
- Surface Mount
- 183" Max Wheelbase, 174.75" Max 2 Wheel Alignment
- Locking Alignment Plates, Auto on/off light feature, Two 7k capacity Rolling Jacks, Stainless Steel Turn Plates



Freight Included

HOFMANN



CL Challenger Lifts



Vehicle, Training & Installation not included



28-TON (56,000 LB.) COMMERCIAL VEHICLE MOBILE COLUMN LIFT - WIRELESS (SET OF 4) #485 80095 00 (MODEL CML-7X4)

\$44,209

FINANCE: \$961.99 / month for 60 months

- Simple: tablet-based touch screen with on-board manuals, videos and Internet
- Broad Application: heavy duty through light duty vehicles
- Fully Adjustable Carriage: 12" forks supports wheel diameter from 5" to 24.5"
- Features the industry's original wireless communication system, state of the art touch screen graphic control system, and a patented self-centering adjustable carriage



Freight Included

AIR LINE KIT #40230-E

\$499

- Internal air line kit for dual rolling jack operation (4P14EFX, 4015E, and 4115E series only)

ROLLING JACK #RJ7.5 JACKS

\$3,469

FINANCE: \$92.00 / month for 60 months

- Air/hydraulic operation
- Adjustable width
- 7,500 Lbs. Capacity for 4p14, 4015 and 4115 series lifts



Freight Included

MAHLE

CL Challenger Lifts



Vehicle, Training & Installation not included



Training & installation not included



Training & installation not included



Vehicle, Training & Installation not included

6,000 LB. LOW-RISE PAD LIFT #LR-60

\$2,899

FINANCE: \$192.70 / month for 60 months

- 26-inch
- Includes 1.5" rubber blocks (set of 4)



Freight Included

10,000 LB. LOW-RISE PAD LIFT (22-3/4") #LR-10000

\$4,409

FINANCE: \$116.93 / month for 60 months

- Includes 4" blocks (2 styles - set of 4 each)



Freight Included

9,000 LB. LOW-RISE PAD LIFT (23") #P9000LT

\$5,759

FINANCE: \$133.72 / month for 60 months

- Pit style
- Includes 3" rubber blocks (set of 4)



Freight Included

7,000 LB. HIGH-RISE PAD LIFT (72") #SP-7XL

\$9,399

FINANCE: \$218.24 / month for 60 months

- Double scissor, Open center
- 6" Low height (ramps in & out)
- Includes 2" rubber blocks (set 4)
- Air lock



Freight Included

BendPak

tire service

ALIGNMENT

MOBILE TABLET ALIGNER #R1065

\$9,949

FINANCE:
\$231.02 / month for 60 months

- Take the tablet wherever you go
- Email results to customer
- Spoiler program for lowered vehicles



GEOLINER™ 630 IMAGING ALIGNER SYSTEM #EEWA721G

\$13,549

FINANCE:
\$307.56 / month for 60 months

- Compact all-in-one installation + an exclusive tilting beam
- Next-generation user interface with intelligent, predictive alignment flow
- Video speed cameras constantly monitor the alignment and provide critical information to get the job done right
- Patented VODI™ guides the technician through the measuring process, reducing the amount of time spent walking back and forth from the vehicle to the aligner



GEOLINER™ 660 IMAGING ALIGNER SYSTEM #EEWA712TH3

\$19,019

FINANCE:
\$431.73 / month for 60 months

- Simple, easy to use software at all rack heights accurate, real-time measurements
- Advanced camera imaging technology
- Video speed cameras constantly monitor alignment
- The camera beam automatically follows the vehicle by tracking the target



CWA 6500 WHEEL ALIGNER #8006500

\$23,299

FINANCE:
\$528.89 / month for 60 months

- Comes with both self-centering clamp and exclusive tire gripping adapters
- Multiple compensation modes
- Two wheel alignment mode
- Standard VIN Scanner
- Mobile Cabinet Supports Using Aligner in Multiple Bays



GEOLINER 678 + AC400 CLAMPS & VIN READER #EEWA715TBV3

\$23,729

FINANCE:
\$538.65 / month for 60 months

- New, intuitive software is designed together with technicians to provide the core alignment functions, only one click away
- Automatic Tracking
- Video Speed Camera
- Intelligent Software Tools
- EZ-Toe



R1080 + 3D WHEEL ALIGNER #R1080

\$25,059

FINANCE:
\$545.82 / month for 60 months

- ADAS compatible software
- Use on multiple lifts
- True 3D Targets
- Extra batteries
- Free 2 Years of database updates



TIRE CHANGERS

SEMI AUTOMATIC TIRE CHANGER #PRO124

\$3,699

FINANCE:
\$98.10 / month for 60 months

- Electric motor
- 11" - 24" external clamping
- 49" tire, 13" width
- Service Pro

ARTICULATING ARM #8-11900263

\$1,099

FINANCE:
\$29.15 / month for 60 months



SWING ARM TIRE CHANGER #R980XR

\$3,759

FINANCE:
\$99.69 / month for 60 months

- Electric motor
- 9" - 28" external clamping, 50" tire, 16" width
- Steel & Nylon Duckhead & Adapter - Hose Bead Blast Only (230V-1PH - 3HP)



SWING ARM TIRE CHANGER #A9222TI-E

\$5,009

FINANCE:
\$116.31 / month for 60 months

- Electric motor
- 10" - 22" external clamping
- 42" tire, 12.5" width
- 2 SPEED
- 110V



SWING ARM + PNEUMATIC ASSIST ARM #R980AT

\$5,279

FINANCE:
\$122.58 / month for 60 months

- Electric motor
- Assist arm on left side
- 9" - 28" external clamping
- 50" tire, 16" width
- Steel & nylon Duckhead & adapter, hose bead blast only (230V-1PH - 3HP)





RC-45E RIM CLAMP TIRE CHANGER #8560994901

\$5,319

FINANCE:
\$123.51 / month for
60 months

- Designed to work on a variety of applications (including most OE)
- Coats quality + durability
- 21" External clamping capability, up to 10.5" rim width & up to 50" overall wheel diameter range
- Air or electric tabletop motor



RC-45A RIM CLAMP TIRE CHANGER #85609949

\$5,749

FINANCE:
\$133.49 / month for
60 months



RC-55E RIM CLAMP TIRE CHANGER #8560995001

\$7,599

FINANCE:
\$175.52 / month for
60 months



RC-55A RIM CLAMP TIRE CHANGER #85609950

\$7,979

FINANCE:
\$185.27 / month for
60 months

60XE RIM CLAMP TIRE CHANGER #80060XEH1

\$8,939

FINANCE:
\$207.56 / month for
60 months

- Built for high-volume shops
- Best-in-class clamping capacity
- Clamping range – 6"-24" upgradeable to 28"
- Tire width: 14" & Max tire diameter – 50"
- Patented Robo-Arm® helper device
- Single point bead sealer + Hand actuated bead loosener
- Air or electric drive



60XA RIM CLAMP TIRE CHANGER #80060XAH1

\$9,359

FINANCE:
\$217.32 / month for
60 months

Manufacturers Setup & Training Included



80XE RIM CLAMP TIRE CHANGER #80080XEH220

\$10,749

FINANCE:
\$244.00 / month for
60 months

- 2 Horsepower, 220V, 14A, 1ph. Motor (20V version)
- NEW & improved Robo-Roller design
- NEW & improved GripMax 2.0 clamps
- NEW Heavier robust chassis



80CEH220 CENTER-POST TIRE CHANGER #80080CEH220

\$11,809

FINANCE:
\$268.06 / month for
60 months

Tire & Wheel not included



SWING ARM TIRE CHANGER #A9824TI-E

\$6,679

FINANCE:
\$155.09 / month for
60 months

- Electric motor, 47" tire, 14" W
- 10" - 24" external clamping
- 2 SPEED & 110V



ARTICULATING ARM #8-11100100

\$1,249

FINANCE:
\$33.12 / month for 60 months



MONTY® 1675 SMARTSPEED #EEWH779CU2

\$8,719

FINANCE:
\$202.46 / month for
60 months

- Extremely rugged, high capacity
- Fast & ergonomic pneumatic vertical arm
- Ergonomic hand operated bead breaker
- Large integrated air tank reduces footprint & increase blasting capabilities
- Max Rim Diameter : 24"
- Max Tire Diameter: 53"
- Max Tire Width: 15"



Tire & Wheel not included



Tire & Wheel not included

9028E RIM CLAMP TIRE CHANGER #8009028

\$12,979

FINANCE:
\$294.62 / month for
60 months

- Tilt-back design
- Robo-Arm powered Assist
- Taper roller cone power assist
- 2 Lifting roller discs
- Best-in-class clamping range: 10" – 28"



Tire & Wheel not included

R146RP SWING ARM TIRE CHANGER AIR + HELPER ARM #RWC246.26iRP

\$7,019

FINANCE:
\$162.98 / month for
60 months

- Includes Helper Arm with Bead Roller
- Plastic mount / demount head reduces damage
- Hand operated bead breaker



MONTY® 3550EM TIRE CHANGER #M3550EM110B

\$9,819

FINANCE:
\$228.00 / month for
60 months

- Push-button controlled mount /demount head pneumatically lowers and locks into position
- Fast and ergonomic pneumatic vertical arm
- Swing arm style mount / demount with a quick-change design
- High capacity tire changer



LEVERLESS TIRE CHANGER #AM-50-AA

\$15,199

FINANCE:
\$345.02 / month for
60 months

- Center post style & Electric motor
- Articulating assist arm
- 12" - 30" Wheel, 47" Tire, 15" width
- Wheel lift + 1 Bead breaker



REVERSE MOUNT WHEEL KIT #8-111000-73

\$799



Tire & Wheel not included

**DUAL ROLLER
CENTER POST
TIRE CHANGER
#RWC1200**

\$17,999

FINANCE:
\$408.58 / month for 60
months

- Two bead rollers makes breaking even the toughest beads easy
- Standard wheel lift reduces operator fatigue
- Center locking system suitable for reverse rims



Tire & Wheel not included

**LEVERLESS
TIRE
CHANGER
#AM-500-AA**

\$18,059

FINANCE:
\$409.94 / month for 60
months

- Center Post Style & Electric motor
- Articulating Assist Arm
- 12" - 32" wheel, 47" tire, 15" width
- Wheel Lift & 2 Bead Breakers

**CLAD WHEEL
ADAPTER
#8-111000-87**

\$799



Tire & Wheel not included



**MONTY 8800
TIRE
CHANGER
#EEWH778AUB**

\$19,849

FINANCE:
\$450.57 / month for 60
months

- Bead Pusher Technology - Integrated bead pusher assists in the mount process of the upper bead.
- Intuitive Control Panel - Simple, color-coded control panel matches machine operating procedures.
- Center Post Clamp - Traditional center post design accommodates a wide range of wheel sizes.



Tire & Wheel not included



WHEEL BALANCERS

**RANGER
WHEEL
BALANCER
#DST2420**

\$2,619

FINANCE:
\$69.46 / month for
60 months

- LED, 36mm, 145 lb unit
- Cones to 5.00"
- Spacer, speed nut, pegs
- Wheel weight starter kit
- 32 Tooth Encoder (110V or 230V-1PH - Dual Motor)



Tire & Wheel not included



**R138 SHOP 2D
WHEEL
BALANCER
#RWB338FMDB**

\$2,879

FINANCE:
\$76.35 / month for 60
months

- 7-Piece double-sided collet kit
- Light truck cone adapter
- Auto stop on top & auto indexing
- Laser line guided adhesive weight placement



**RANGER
WHEEL
BALANCER
#DST30P**

\$2,929

FINANCE:
\$77.68 / month for
60 months

- LED, 36mm, 150 lb unit, cones to 5.00"
- Wheel weight starter kit
- 64 Tooth Encoder (110V or 230V-1PH - Dual Motor)



Tire & Wheel not included



**CORGHI
WHEEL
BALANCER
#PRO750**

\$3,979

FINANCE:
\$105.52 / month for
60 months

- LED, 40mm
- Auto Distance/Diameter
- 144 lb unit
- Cones to 4.00" (3)
- 110V



Tire & Wheel not included



**RANGER
WHEEL
BALANCER
#LS43B**

\$4,029

FINANCE:
\$106.85 / month for
60 months

- LED, 36mm, 145 lb unit
- Cones to 5.00"
- Spacer, speed nut, pegs
- Wheel weight starter kit
- (230V-1PH)



Tire & Wheel not included



**885 WHEEL
BALANCER,
110V
#800885**

\$4,259

FINANCE:
\$112.95 / month for
60 months

- Automatic Wheel Data Entry
- Direct Tape-A-Weight™
- Auto Start Hood
- Integrated LED Display
- Standard 110V Power



Tire & Wheel not included



**DIGITAL
WHEEL
BALANCER
#EM9250**

\$4,829

FINANCE:
\$128.07 / month for
60 months

- LED, 40mm
- Auto Distance/Diameter
- 165 lb. unit
- Cones to 4.66"
- Speed Nut
- Laser & LED
- 110V



Tire & Wheel not included



**1185 WHEEL
BALANCER,
110V
#8001185**

\$5,099

FINANCE:
\$118.40 / month for
60 months

- Color LCD Video Display
- Bottom Dead Center Laser
- Position indexing
- Small chassis, 110V



Tire & Wheel not included



1300 DIRECT DRIVE WHEEL BALANCER, 220V, 1PHASE #80013002D

\$6,069

FINANCE: \$140.92 / month for 60 months

1300 DIRECT DRIVE WHEEL BALANCER, 220V, 3P #80013002D01

- Max tire diameter 44"; Max rim diameter 30"
- Auto distance & diameter entry
- Direct tape-a-weight measurement
- Static on screen
- Includes 4 centering cones & adapters



Tire & Wheel not included



R155 PRO 3D WHEEL BALANCER + 7-PC COLLET KIT #RWB355SB

\$6,329

FINANCE: \$146.96 / month for 60 months

- Easy operation
- Stop On Top & Auto Indexing
- Smart Static Mode
- Wheel width gauge included
- 19" Monitor
- 6 second cycle time
- Automatic entry of distance, diameter, & width



Tire & Wheel not included



GEODYNA 7600P WHEEL BALANCER #EEWB765AP

\$7,649

FINANCE: \$177.61 / month for 60 months

- New touchscreen, user-friendly interface on a flat panel, resistive touch display
- Fast and intuitive selection of the cycle modes
- easy WEIGHT - Pinpoint indicator light
- Always clamps the wheel accurately with a constant force



Tire & Wheel not included

WHEEL BALANCER WITH LCD MONITOR #EM9280

\$7,449

FINANCE: \$174.13 / month for 60 months

- Monitor, 40mm
- Auto Distance/Diameter
- 165 lb. unit
- Cones to 4.66"
- Speed Nut
- Laser & LED
- 110V



Tire & Wheel not included



1500 DIRECT DRIVE WHEEL BALANCER, 220V, 1P #80015003D

\$9,259

FINANCE: \$214.99 / month for 60 months

1500 DIRECT DRIVE WHEEL BALANCER, 220V, 3P #80015003D01

- Motor & spindle are combined into a single, pre-balanced assembly that always stays calibrated to zero
- Pinpoints the exact weight location, both radially & axially
- Automatically positions wheel at weight placement location & locks spindle in place



Tire & Wheel not included



CORGHI HD WHEEL BALANCER #ET66WL

\$11,099

FINANCE: \$251.95 / month for 60 months

- LED, 46mm
- Auto Distance, 440 lb. unit
- Cones 6.20" to 7.90" & 8.6" to 11"
- Wheel lift
- 110V



Tire & Wheel not included



1600 DIRECT DRIVE WHEEL BALANCER, 220V, 1P #80016003D

1600 DIRECT DRIVE WHEEL BALANCER, 220V, 3P #80016003D01

- Maximum tire diameter 44"
- Maximum rim diameter 30"
- Auto distance & diameter data entry
- Behind the spoke mode
- 1-1/3 HP Direct drive motor, 220V, 1 Phase



Tire & Wheel not included



GEODYNA® 8200P LED DISPLAY WHEEL BALANCER (115V-1PH) #EEWB766BE5

\$11,539

FINANCE: \$264.94 / month for 60 months

- Radial Run-Out - High-accuracy laser technology measures degree of deviation from a perfect circle, enabling match-mounting to improve roundness and reduce geometric vibrations
- Electromechanically clamps the wheel accurately with a constant force
- User Interface - Highly intuitive touchscreen user interface allows for rapid, time-saving selection of cycle modes: fully automatic with spoke detection, fast automatic without spoke detection and manual



Tire & Wheel not included

VALUE COMBOS

TIRE CHANGER + WHEEL BALANCER COMBO

#8500300350 (MODEL BL300)

- 1HP Electric motor for steel & alloy wheels
- Air powered side bead loosener
- Bead sealing jets aid in inflation
- Clamping capability up to 24" externally
- 6-Month parts warranty
- Includes lube applicator, lube bottle, bead lift tool, hose with air chuck, inflation pressure regulator & patented oil injection /lubrication system with large oil reservoir



BASELINE

\$5,249

FINANCE:
\$121.88 / month for 60 months

MONTY 1270 + GEODYNA 7100 COMBO #HOFCOMBO1

- Strong rugged design ensures long service life
- Mounting arm swings to the side allowing space saving installation directly against a wall
- Semi-automatic input of offset and rim diameter via 2D SAPE
- Conspicuous and intuitive LED display



HOFMANN

Tire not included.

\$5,449

FINANCE:
\$126.53 / month for 60 months

VALUE COMBO: TIRE CHANGER & BALANCER #RW138140C

\$5,859

FINANCE:
\$136.05 / month for 60 months

Includes:

- R140i Swing Arm Tire Changer
 - Swing arm changer
 - Hand controlled side bead breaker
- R138 Shop 2D Wheel Balancer
 - Heavy duty shaft and large offset
 - Large digital display



Tire not included.



COMBO SET: LIFT + CHANGER + BALANCER #146148L10K

\$13,899

FINANCE:
\$315.51 / month for 60 months

R146RP AIR SWING ARM TIRE CHANGER #RWC246.261RP

- Air operated
- Helper arm with bead roller
- Plastic mount/demount head
- Hand operated bead breaker
- 3-Year parts
- 1-Year labor warranty



R155 3D WHEEL BALANCER + 7-PC COLLET KIT #RWB355SB

- Auto stop on top & indexing
- Laser line guided adhesive weight placement
- 3-Year parts
- 1-year labor warranty



Tire not included.

10,000 LB. 2-POST LIFT #110

- SPOT RITE ARMS position behind the column
- Direct pull cylinders & Round adapters & extensions
- 12 months parts & labor warranty



Vehicle not included.



GEOLINER™ 770 + AC400 #EWA752BV3

\$26,189

FINANCE:
\$569.87 / month for 60 months

- Exclusive fully portable system
- The camera beam automatically tracks the vehicle allowing comfortable alignment at all rack heights
- Provides optimum placement of the advanced XD targets and cameras for more speed and more accuracy



HOFMANN

ALIGNMENT COMBO: 4-POST + ALIGNER #CRA14R1070

\$26,999

FINANCE:
\$587.50 / month for 60 months

- CRA14N201
 - Forward 14,000 lb. Alignment Lift
 - 182.5" Wheel Base
- RWA1070WS
 - Rotary R1070 8CCD Wheel Alignment System



TPMS

**TSGUN
TPMS
TOOL**
#301180825

\$149

- Bluetooth TPMS add on tool, works with Launch Pro line diagnostic scanners
- Extensive vehicle coverage of Euro, Asian and Domestic applications
- TPMS sensor activation reading, diagnosis, relearn and program
- 98% TPMS application coverage
- 315/433Mhz sensor capability



**LAUNCH
CRT511
PRO**
#301050570

\$299

- New CRT511 TPMS with 4 rubber & 4 metal TPMS sensors
- Activate and match 315 / 433 Mhz sensors
- Reset, relearn, reprogram & diagnose TPMS sensors
- Fast relearn operation with step by step tips read & clear TPMS DTC's



**SMART SENSOR ELITE
PROGRAMMING &
DIAGNOSTIC TOOL**
#17-140

\$799

- Comprehensive relearn procedures built-in
- Easy to follow icon based interface
- Perform both stationary & OBD II relearns
- Read sensor IDs by OBD II & copy directly onto a smart device
- Captured Tire Identification Number (TIN)
- Includes: Smart Sensor Elite User Guide & Programming & Diagnostic Tool, Micro USB Data Cable & Charger, Commercial Grade OBD II Cable & TPMS Activation Magnet



LAUNCH

**Xtra
seal**

**MAXITPMS TS508K-1
TPMS SERVICE
TOOL**
#TS508K-1

\$329

- 8 Autel 1-Sensors Included
- Quick Mode & Advanced Mode Options
- Read/Activate/Relearn All Known Sensors
- Detect & Display TPMS System Faults
- Display Vehicle-Specific Relearn Procedures; Perform OBDII Relearns



**MAXITPMS TBE200 TIRE
TREAD & BRAKE DISC
WEAR EXAMINER**
#TBE200

\$449

- Laser-Enabled
- 1.65" AMOLED Super Retina Touchscreen Display
- Full Color Graphical Display
- Compatible with Passenger, Commercial & Off-road Vehicles
- Displays Recommendations for Tire & Brake Disc Replacement, 4-wheel Alignment & Tire Rotation
- Scan Tire Identification Number (TIN)



**MAXITPMS ITS600
TPMS DIAGNOSTICS &
SERVICE FUNCTIONS**
#ITS600

\$499

- Activates, reads & relearns all known sensors
- (4) MX-Sensor Program Modes
- Batch Program Up to 20 MX-Sensors
- 5.5" Color Display; Android 9.0 OS
- Includes Wireless Bluetooth Vehicle Communication Interface
- Enhanced At-a-Glance Diagnostics Status Screen
- Rapid VIN Acquisition Via Optical VIN scan Function
- Read/Erse All System Codes and Perform OLS, BMS, SAS and EPB



AUTEL

**AUTODIAGNOS™
TPMS D TOOL BUNDLE**
#2910002560100

\$599

- Includes 24 REDI-Sensors
- Triggers, diagnoses, and reads 100% of OE and aftermarket passenger vehicle sensors
- Configure sensors by create, copy, copy by set and copy by OBD-II
- Complete TPMS diagnostics - read and clear codes
- OBD-II mode relearns sensors in under 2 minutes
- Barcode scanner for VIN detection
- 5 years of free updates
- 3 Year Warranty

**AUTODIAGNOS™
TPMS SE TOOL BUNDLE**
#2910002560200

\$1,249

FINANCE: \$33.12 / month for 60 months

- Includes 12 REDI-Sensors
- Triggers, diagnoses, and reads 100% of OE and aftermarket passenger vehicle sensors
- Relearn coverage for 98.6% of domestic, Asian and European passenger vehicles
- 5 years of free updates
- 3 Year Warranty



bundle & save

Continental

24-DRAWER RITE-SENSOR® CABINET

\$369



#RS-1000-CAB03

- Includes \$600+ in sellable merchandise!
- 315 of the most popular TPMS Service Kits
- Honda, Acura, Toyota, Lexus, GM, Ford, Nissan, Infiniti, Hyundai, Kia and more!
- OE Sensor Sensor Kits
- OE Sensor Aluminum Valve Kits
- OE Sensor Rubber Valve Kits

Service Kits:
\$624 VALUE

TECHRITEPRO BUNDLE TOOL KITS

- Includes tool, OBDII cable, Power Supply, Quick Start Guide and Rite-Sensors® (rubber stem only)
- Low cost, fully functioning TPMS Tool
- RITE-SENSOR® RITE-SYNC® Process Enabled
- Extended OBDII Coverage
- High resolution 2.8" color display with Bluetooth Capability
- One Year Software!
- One Year Warranty!



#WRTRP100-RS4

\$349

4 RITE-SENSORS® WITH RUBBER STEMS INCLUDED • VALUE: \$158

#WRTRP100-RS8

\$419

8 RITE-SENSORS® WITH RUBBER STEMS INCLUDED • VALUE: \$316

#WRTRP100-RS12

\$489

12 RITE-SENSORS® WITH RUBBER STEMS INCLUDED • VALUE: \$474

24-DRAWER RITE-SENSOR® CABINET

#RS-1000-CAB02

\$650

- Includes \$1,400+ in sellable merchandise!
- 20 RITE-SENSORS® (rubber stem only)
- 315 of the most popular TPMS Service Kits
- Honda, Acura, Toyota, Lexus, GM, Ford, Nissan, Infiniti, Hyundai, Kia and more!
- OE Sensor Sensor Kits
- OE Sensor Aluminum Valve Kits
- OE Sensor Rubber Valve Kits



\$1,414 VALUE

TECH450PRO TOOL

#WRT450PRO-RS24P

\$750

- Includes 24 RITE-SENSORS®: \$948 Sensor value
- Extended OBDII coverage
- Wi-Fi updating & Bluetooth Capability
- Two year's software and warranty



PROMO: 24 RITE-SENSORS® WITH RUBBER STEMS INCLUDED • VALUE: \$948

TECH600PRO RITESENSOR® BUNDLE KIT

#WRT600PRO-RS30P

\$1,049

FINANCE:
\$27.82/month for 60 months

- Includes the Tech600Pro tool, Wireless VCI, Power Supply, USB Cable, Quick Start Guide and 30 RiteSensors®



PROMO: 30 RITE-SENSORS® WITH RUBBER STEMS INCLUDED • VALUE: \$1,185

TECH600PRO TOOL KIT

#WRT600PRO

\$1,069

FINANCE:
\$28.35/month for 60 months

- High resolution 2.8" color display
- Integrated Wi-Fi
- Wireless VCI & inductive charging wall cradle
- Graphical user interface
- Faster tool response and operation
- Programs aftermarket TPMS Sensors
- Packed in a hard case
- Two year warranty



ONE-STOP SHOP
for everything **TPMS**

BARTEC USA
TPMS PROFESSIONALS

TPMS SNAP-IN VALVE GM
#17-20008

\$3⁹⁹

- Self tapping screws
- 11.5" / lbs. screw torque
- 80 PSI maximum cold inflation pressure
- GM TPMS snap-in valve



MX-SENSOR 1-SENSOR
#1-SENSOR

\$29⁹⁹

- Choice of rubber or metal stems
- Combined Frequency: 315MHz & 433MHz
- Programmable with Autel TPMS Service Tools
- Exclusive Press Release Button to Easily Replace Valve Stems
- Program to Replace 99% of OE Sensors
- Compatible with Autel Interchangeable Rubber, Aluminum or Color Valve Stems



LTR-01 TPMS SENSOR RUBBER
#301050559

\$29⁹⁹

- Programmable universal replacement TPMS sensor
- Meets original equipment quality and performance standards
- Combines 315 and 433 Mhz applications into one sensor
- 3 to 5 year battery life

LTR-01 TPMS SENSOR METAL
#301050540

\$29⁹⁹



UNIVERSAL MULTI-FREQUENCY SMART SENSORS
#17-43041 & #17-43042

\$39⁹⁹

- 17-43041 Universal Sensor With Rubber Snap-In Valve
- 17-43042 Universal Sensor With Aluminum Clamp-In Valve
- Universal Sensors Combine 314.9MHz & 433.92 MHz all in ONE Sensor
- Programmable with Smart Sensor Elite & Pro+ Activation Tools



RITE-SENSOR SLEEVE PACK: 10 SENSORS
#RS-1000-10

\$329

- Single SKU Solution
- Choice of metal or rubber stem
- RITE-SYNC® Technology built-in
- Dual Frequency [315 & 433 MHz]
- Built to OEM Specifications
- Programs in less than 3 seconds
- Available in 120 unit master case!
- Limited lifetime warranty



RITE-SENSOR BULK PACK: 24 RUBBER STEM SENSORS
#RS-1000-24B

\$569

- Single SKU Solution
- RITE-SYNC® Technology built-in
- Dual Frequency [315 & 433 MHz]
- Built to OEM Specifications
- Programs in less than 3 seconds
- Available in 120 unit master case!
- Limited lifetime warranty



DIGITAL TIRE INFLATOR
#M525

\$24⁹⁹

- Measure tire pressure from 0-150 PSI, 20-1000 kpa
- Change digital readout between PSI, kpa, bar & kg/cm2
- Includes 2 AAA batteries, 1/4" male inlet, & valve core tool
- Built-in bleed button for lowering pressure



DIGITAL TIRE INFLATOR
#BSTDTI020

\$59⁹⁹

- Clear & easy to read display
- Modern, lightweight & shock resistant
- Two button operation
- Long battery life with low battery warning
- 21" hose with quick connect
- Accuracy: +/- 0.1 PSI
- Pressure range: 7-174 PSI
- 1 Year Warranty



CHEMICAL VULCANIZING CEMENT
#14-008

\$7⁹⁹

- For use with an X-tra Seal repair unit or insert
- Fast Drying
- For Chemical or Heat Vulcanization



X-TRA SEAL EURO PASTE (WHITE) 6.5 LB. TUB
#14-699

\$14⁹⁹

- Low profile bucket
- Wax paste lubricant that works great with low profile, run flat & allow wheel applications
- No mixing, no water, dries tacky
- Rust inhibitors



EURO PASTE APPLICATOR BRUSH (1" DIAMETER)
#14-711

\$16⁹⁹

- For the application of euro paste



NYLON MOUNT HEAD FOR SNAP-ON & HOFMANN TIRE CHANGERS
#14-969

\$49⁹⁹

- Replaces Snap-On 20024335, Hofmann ST0024335



Xtra seal

NYLON TOOL HEAD FOR HUNTER TCA34 TIRE CHANGERS
#14-972W

\$49⁹⁹

- Replaces hunter part number rp6-710014120
- Fits hunter tca34 tire changers With serial numbers 664 & above



TIRE REPAIR CABINET ASSORTMENT
#14-603

\$599

- Tire Service System with Deluxe Wall Cabinet
- Includes: Over 110 industry standard puncture repairs
- Includes all tools needed for tire repair service; reversible drill, XLIGHT, air powered vacuum, carbide cutters, & more



PORTABLE TIRE BEAD SEATER
#W10012

\$119

- 5-Gallon tire bead seater for cars, trucks, 4 x 4s, ATVs, tractors & lawn equipment
- Portable, no need for larger stationary equipment
- Heavy-duty ball air inlet & exhaust port valves
- Seats beads on tires simply, safely & fast
- Seats tires up to 25.5"



PT Performance Tool

TIRE TAXI
#JDI-TT1

\$89⁹⁹

- Specifically designed to make moving tires throughout the service bays simple, fast & safe
- Holds up to 5 tire & wheel assemblies or 8 tires
- 4 Heavy-duty swivel casters allow the Tire Taxi to rotate 360°
- Includes 1 locking caster for stability



Tire & wheel not included.

TIRE TAXI EXTENDED
#JDI-TT1-EX

\$199

- Designed to create a more ergonomic working height
- Has 4 legs that extend the overall height to 23"

Tire Taxi
Transporting Tires The Easy Way

TIRE CAGE
#2220

\$329

- 2 Bar truck
- Portable super single
- Inside dimensions: 54 H x 21.5 W x 17 L



TIRE CAGE
#2230

\$389

- 3 Bar truck
- Inside dimensions: 54 H x 21.5 W x 20 L



Tire & wheel not included.

TIRE CAGE
#2240

\$439

- 4 Bar truck
- Inside dimensions: 54 H x 21.5 W x 28 L



Tire & wheel not included.

TIRE SPREADER
#5045

\$629

- Manual style with light, rollers & shock
- Adjustable spread hooks
- Ship by dim weight: 47 H x 23 W x 16 L



Branick
Since 1917

TIRE CART
#TC400

\$649

- Solid tires
- 5 Per pallet



TIRE SPREADER
#5120

\$2,189

FINANCE:
\$58.05 / month for 60 months

- Air-powered



lifts & hydraulics

JACK STANDS

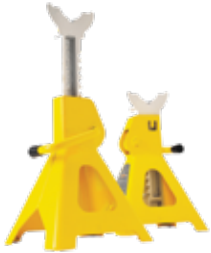

2-TON RATCHET JACK STANDS #W41021

• 10 3/8" to 16 3/8" range

\$39⁹⁹



3-TON RATCHET JACK STANDS #3303

\$69⁹⁹



4-TON JACK STAND SETS #55040

\$69⁹⁹

3-TON RATCHET JACK STANDS #W41022

• 12" to 17 1/4" range

\$42⁹⁹

6-TON RATCHET JACK STANDS #3306

\$119

6-TON JACK STAND SETS #55060

\$119

6-TON RATCHET JACK STANDS #W41023

• 15 1/2" to 23 1/2" range

\$69⁹⁹

12-TON RATCHET JACK STANDS #3312C

\$229

- Multi-position ratchet bar locks into place
- Wide pyramid base for added support
- Large saddle allows better contact with load
- High-grade forged steel & welded frame design
- Ratchet bar constructed with ductile iron

- Multi position ratchet bar locks into place
- Wide pyramid base provides added support
- Large saddle allows better contact with load

22-TON PIN-STYLE JACK STAND SET #55220A

\$219

- Large v-shaped saddle
- Pin style design provides maximum security
- Multiple hole locations for quick & easy adjustment
- Heavy gauge-steel frame design
- Height adjustment pin is tethered to stand

22-TON PIN-STYLE SAFETY STAND #6522

\$259

- Large V-shaped saddle allows better contact with load
- Heavy gauge steel frame prevents warpage
- Adjust to four positions from 12"-20"
- Tethered height adjustment pin



25-TON COMMERCIAL VEHICLE SUPPORT STANDS

- Built to meet or exceed AMSE PASE 2014 standards, all stands feature a tabbed bottom
- Manufactured by Gray in the U.S.
- Utilize a manual insert, load retention pin
- Pin includes flanged design to ensure proper locking
- Sold in pairs



25-TON PIN-STYLE JACK STAND PAIR #81225I

• 12"-20" Height

\$299



#485 80010 00 (MODEL CSS-25)

• Minimum start height: 12" (30 cm)

\$939

#485 80011 00 (MODEL CSS-25T)

• Tall

\$1,079

FINANCE: \$28.62 / month for 60 months



BOTTLE JACKS



SUPER DUTY BOTTLE JACKS

- Heavy duty base
- Adjustable top screws
- Patented Bypass device for safety
- Ideal for auto, truck, farm, & shop use



SUPER DUTY BOTTLE JACKS

- Super duty capacity ranging from 2 to 50-Ton
- Welded cylinder for maximum strength
- High grade steel construction
- Forged and welded base for extra durability
- Leak free operation



| | |
|------------------------|--------------------------|
| 2-TON #W1621 | \$19⁹⁹ |
|------------------------|--------------------------|

| | |
|-------------------------|--------------------------|
| 12-TON #W1632 | \$50⁹⁹ |
|-------------------------|--------------------------|

| | |
|-----------------------|--------------------------|
| 2-TON #3602 | \$39⁹⁹ |
|-----------------------|--------------------------|

| | |
|------------------------|--------------------------|
| 12-TON #3612 | \$89⁹⁹ |
|------------------------|--------------------------|

| | |
|------------------------|--------------------------|
| 4-TON #W1623 | \$24⁹⁹ |
|------------------------|--------------------------|

| | |
|--------------------------------|--------------------------|
| 20-TON SHORTY #W1644 | \$69⁹⁹ |
|--------------------------------|--------------------------|

| | |
|-----------------------|--------------------------|
| 4-TON #3604 | \$49⁹⁹ |
|-----------------------|--------------------------|

| | |
|-------------------------------------|--------------|
| 20-TON LOW-PROFILE #3620S | \$139 |
|-------------------------------------|--------------|

| | |
|------------------------|--------------------------|
| 8-TON #W1628 | \$44⁹⁹ |
|------------------------|--------------------------|

| | |
|-------------------------|--------------------------|
| 20-TON #W1633 | \$79⁹⁹ |
|-------------------------|--------------------------|

| | |
|-----------------------|--------------------------|
| 6-TON #3606 | \$49⁹⁹ |
|-----------------------|--------------------------|

| | |
|------------------------|--------------|
| 20-TON #3620 | \$149 |
|------------------------|--------------|

| | |
|--------------------------------|--------------------------|
| 12-TON SHORTY #W1643 | \$45⁹⁹ |
|--------------------------------|--------------------------|

| | |
|-------------------------|--------------|
| 50-TON #W1637 | \$219 |
|-------------------------|--------------|

| | |
|-----------------------|--------------------------|
| 8-TON #3608 | \$69⁹⁹ |
|-----------------------|--------------------------|

| | |
|------------------------|--------------|
| 30-TON #3630 | \$289 |
|------------------------|--------------|

| | |
|-------------------------------------|--------------------------|
| 12-TON LOW-PROFILE #3612S | \$79⁹⁹ |
|-------------------------------------|--------------------------|

| | |
|------------------------|--------------|
| 50-TON #3650 | \$479 |
|------------------------|--------------|

| | |
|--|--------------|
| 20-TON AIR ASSIST BOTTLE JACK #54200 | \$269 |
|--|--------------|

- External return springs
- Fully welded canister
- Effortless aluminum air motor design
- Safety bypass system



| | |
|---|--------------|
| 20-TON SD LOW PROFILE AIR/HYD BOTTLE JACK #5621SD | \$379 |
|---|--------------|

- Spring assisted return
- Fully welded tank and frame
- Shielded release screw prevents accidental lowering
- Extra thick base
- Specially engineered motor



| | |
|---|--------------|
| 20-TON SD AIR/HYD BOTTLE JACK #5620SD | \$429 |
|---|--------------|

- Spring assisted return
- Fully welded tank & frame
- Shielded release screw prevents accidental lowering
- Extra thick base
- Specially engineered motor

| | |
|--|--------------|
| 30-TON SD AIR ASSISTED BOTTLE JACK #5630SD | \$499 |
|--|--------------|

- Spring assisted return
- Fully welded tank and frame
- Shielded release screw prevents accidental lowering
- Extra thick base
- Specially engineered motor



JACK STANDS

| | |
|--|--------------|
| 1,650 LB. UNDERHOIST STAND + FOOT PEDAL #3320A | \$149 |
|--|--------------|

- Adjusts from 54-1/2" to 80-1/2"
- 12" diameter base.
- Bearing included
- Designed to support vehicle components, not the vehicle.



| | |
|---|--------------|
| 3/4-TON FOOT PEDAL UNDER HOIST JACK STAND #81034A | \$159 |
|---|--------------|

- 55"-81" Height



| | |
|---|--------------|
| 1 1/2-TON TRIPOD STYLE UNDER HOIST JACK STAND #81035A | \$169 |
|---|--------------|

- 49"-85" Height



ENGINE STANDS

750 LB. ROLLING ENGINE STAND #W41037

\$99⁹⁹

- 750 lb. capacity
- Adjustable Width & Depth for most engines
- Heavy Duty 3" casters for easy rolling
- Adjustable cam buckle straps included



1,000 LB. ENGINE STAND #W41025

\$119

- Heavy-duty swivel casters
- Head rotates 360° & locks in 6 positions
- Securely holds most foreign & domestic engine blocks
- Fully adjustable mounting head assembly
- Rugged, heavy-gauge tubular steel construction



1,250 LB. ENGINE STAND + PARTS TRAY #W41031

\$159

- Stable 4-wheel design
- Head rotates 360° & locks in 6 positions
- Sturdy metal parts tray
- Securely holds most foreign & domestic engine blocks
- Fully adjustable mounting head assembly
- Rugged heavy-gauge tubular steel construction



4,400 LB. FOLDABLE ENGINE CRANE #3582

\$699

- Folds up for easy storage
- Boom extends from 40" to 63"
- 69" base length
- Designed for easy and efficient removal & transport of engines



BODY FRAME KITS



BODY FRAME KITS

- HD pump, multiple extensions, accessories + case
- Parts are interchangeable + All steel construction

4-TON #58040

\$309

10-TON #58100

\$409



BODY REPAIR KITS SD

- Long handle & dual piston pump design + Forged steel adapters
- Meets or exceeds ASME/PASE 2014 standards

4-TON #816SD

\$359

10-TON #817SD

\$499

20-TON #819SD

\$1,199
FINANCE:
\$31.80 / month for
60 months



- Pump gauge included to enable pump user to know tonnage being applied
- "Quick-Lock" design for fast and easy assembly and disassembly
- Long handle provides ease of pumping

4-TON HYDRAULIC PORTO-POWER COLLISION REPAIR KIT (FORGED) #904004C

\$419

10-TON HYDRAULIC PORTO-POWER COLLISION REPAIR KIT (FORGED) #910005C

\$659



JACKS

2-1/4-TON TROLLEY JACK #W1611

\$84⁹⁹

- 4,500 lb. capacity
- Steel lifting saddle with 360° swivel
- Clean & easy storage with included blow-molded plastic case



3-TON VIKING HEAVY-DUTY FLOOR JACKS #53300

\$299

- Swivel casters
- Heavy duty construction for increased strength
- Double pump hydraulic system
- Powder coat paint prevents corrosion & scratch resistance
- Bulk quantity pricing available



3.5-TON LOW-PROFILE JACK #W1645

\$319

- 3-1/2" to 20-1/2" Lift range
- Double pump mechanism for quick lifting
- Rubber saddle pad included



JACKS

3.5-TON VIKING HEAVY DUTY FLOOR JACKS
#53350

\$359

- Crowned front wheels



4-TON HEAVY-DUTY FLOOR JACK
#400SS

\$419

- Twin hydraulic system
- Heavy duty pump, ram, & cylinders are precision machined & inspected
- High grade U-cup seals & high pressure plunger
- Rear mounted swivel casters



3.5-TON & 6-TON SAFETY STANDS
#53350JPK

\$449

- 2 PC handle includes bumper pad for vehicle protection



2-TON LOW PROFILE JACK
#200T

\$499

- Super low pickup height of 2 3/4"
- Twin hydraulic system
- Universal joint technology & precision release valve
- Tough UV powder coated frame
- One piece foam covered 50" handle



3.5-TON PROFESSIONAL HD FLOOR JACK
#350SS

\$509

- Low pickup height of 4"
- Twin hydraulic system
- Universal joint technology & precision release valve
- Tough UV powder coated frame
- Rear mounted 2.75" swivel casters



3-TON ALUMINUM RACING SERVICE JACK
#210

\$579

- Lightweight anodized aluminum frame
- Wiper seals prevent dirt from entering hydraulic system
- Lifts with fewer pumps than similar styles
- 2 side handles for easy positioning



22-TON AIR ASSIST TRUCK AXLE JACK
#56220A

\$619

- Narrow chassis design
- Jumbo wheels
- Fully welded canister
- Special release valve operations with the handle in any position
- Built-in safety valve



22-TON AIR / HYD AXLE JACK + 3PC EXT KIT
#565F

\$699

- Unique motor designed
- Precision machined parts
- Large wheels
- External return springs



20-TON BOTTLE STYLE AIR/HYD TRUCK JACK
#72090A

\$629

- Lightweight
- 8.75" Low Height



20-TON BOTTLE STYLE AIR / HYD TRUCK JACK
#72080A

\$639

- Lightweight
- 11.13" Low Height

10-TON CYLINDER STYLE AIR JACK
#82990C

\$959

- 172PSI
- 18"-49" Height, 11-1/2" Stroke
- Portable



22-TON AIR / HYDRAULIC TRUCK JACK
#72200D

\$969

- 1-PC Handle
- 3 Extensions / 1 Saddle & Holder
- 9.00" low height



20-TON DRIVE-ON RAMPS TRUCK SERVICE
#82020

\$999

- 16" Tread Width
- Pair - 10-Ton Each



10-TON AIR-LIFT JACK
#3400A

\$1,099

FINANCE:
\$29.15 / month for 60 months

- 10-ton capacity achieved at 200-PSI air supply
- Low height 18" to high height with all extensions used 52"
- Heavy-duty air valve offers accurate lift control
- Removable "T" handle for easy storage
- Extension tubes offer multiple lifting and locking positions
- 12" Lift travel



20-TON TRUCK RAMPS (WIDE)
#3420ASD

\$1,199

FINANCE:
\$31.80 / month for 60 months

- Long retractable handle and wheels
- Suitable for large truck tires up to 16" maximum width
- Comes with rubber nonskid pad
- 20-Ton capacity per pair
- Frame: 47" L x 18.25" W x 9.25" H
- Overall length: 51"
- Tread Width: 16"



LONG-CHASSIS SERVICE JACKS

- Long 56" body for easier lifting of vehicle with long overhangs
- Foot-operated pump for quick lifting efficiency
- Automatic overload safety valves
- Swivel casters for ease of maneuverability in tight shop situations
- Large, rugged 4-1/2" front wheels and 2-3/4" rear casters

| | | |
|--|---|--|
| 5-TON #3120 • Long 56" body for easier lifting of vehicle with long overhangs | \$1,199 FINANCE: \$31.80 / month for 60 months | |
| 5-TON AIR / HYD #3125 • Long 61" body for easier lifting of vehicle with long overhangs | \$1,299 FINANCE: \$34.45 / month for 60 months | |
| 10-TON AIR / HYD #3135 • Long 61" body for easier lifting of vehicle with long overhangs | \$1,699 FINANCE: \$45.06 / month for 60 months | |
| 20-TON #3220 • Long 61" body for easier lifting of vehicle with long overhangs | \$2,699 FINANCE: \$71.58 / month for 60 months | |
| 20-TON AIR / HYD #3225 • Long 61" body for easier lifting of vehicle with long overhangs | \$2,999 FINANCE: \$79.53 / month for 60 months | |



3-TON JACK SERVICE
#485 80022 00 (CSJ-3)

\$1,499
 FINANCE:
 \$39.75 / month for 60 months

- USA Made
- Limited Lifetime Warranty
- 6,000 lb. Capacity

MAHLE



FOOT PEDAL SERVICE JACKS

| | | |
|---|---|--|
| 5-TON #71500G • 5.63" - 27.25" Lift Height | \$1,299 FINANCE: \$34.45 / month for 60 months | |
| 5-TON AIR / HYD #71550G • 5.63" - 27.25" Lift Height | \$1,599 FINANCE: \$42.41 / month for 60 months | |
| 10-TON #71000D • 6.13" - 27.25" Lift Height | \$2,189 FINANCE: \$58.05 / month for 60 months | |
| 10-TON AIR / HYD #71100A • 6.13" - 27.25" Lift Height | \$2,629 FINANCE: \$69.72 / month for 60 months | |

norco
 PROFESSIONAL LIFTING EQUIPMENT

COMMERCIAL VEHICLE SERVICE JACKS

- American designed & manufactured
- A low start height combined with a high lift height accommodates a variety of vehicles
- Heavy duty steel frame design stands up to the most vigorous shop use
- Manual pump feature included
- Large front wheels & long-life heavy duty rear swivel casters



6-TON - AIR ASSIST
#485 80024 00 (MODEL CSJ-6A)

\$3,709
 FINANCE:
 \$98.36 / month for 60 months

10-TON
#485 80023 00 (MODEL CSJ-10A)

\$4,469
 FINANCE:
 \$118.52 / month for 60 months

MAHLE



TRANSMISSION JACKS

| | | | | | |
|---|--------------|---|---|---|--|
| 1/2-TON TRANSMISSION JACK #W1607 • Min clearance: 8.66"; Max height: 22.64" • Built-in safety overload system • Expanded saddle: 17" x 9-3/8" • Handle length: 22-1/2" • Saddle base: 12-5/8" x 7-7/8" • Meets ASME/ANSI-PALD safety standards | \$249 | 1/2-TON TRANSMISSION JACK #72550B • Upright • Manual, Foot Pedal, Double Pump • 35" - 72" Height (FASTJACK) | \$1,199 FINANCE: \$31.80 / month for 60 months | TRUCK TRANSMISSION JACKS • Fully adjustable saddle with corner brackets and safety chain • 24" handle pivots 360° around pump • Industrial grade 3" casters. • Engineered with a safety overload bypass system | 1,000 LB. #3171A \$799 |
| | | | | | 2,000 LB. #3172A \$1,199 FINANCE: \$31.80 / month for 60 months |
| | | | | | 3,000 LB. #3179A \$1,699 FINANCE: \$45.06 / month for 60 months |
| | | | | | 4,400 LB. #3180A \$1,799 FINANCE: \$47.71 / month for 60 months |

PT
 Performance Tool

norco
 PROFESSIONAL LIFTING EQUIPMENT

AFF

TRANSMISSION JACKS

TELESCOPIC TRANSMISSION JACKS

- Double pump hydraulic system delivers quick lift
- Powder coat paint provides scratch & corrosion resistance
- Chrome plated components reduce friction
- Adjustable saddle with corner brackets & safety chain

**1,100 LB. AIR-ASSIST
#3052A**

\$1,099
FINANCE:
\$29.15 / month
for 60 months

**1,100 LB. MANUAL
#3052**

\$999

**2,000 LB. MANUAL
#3102**

\$1,099
FINANCE:
\$29.15 / month
for 60 months

**2,000 LB. AIR ASSIST
#3102A**

\$1,199
FINANCE:
\$31.80 / month for 60
months



**1,000 LB. AUTOMOTIVE
TRANSMISSION JACK
HIGH RISE MODEL ATJ-1000H**
#485 80025 00 (MODEL ATJ-1000H)

\$2,579
FINANCE:
\$68.40 / month for
60 months

- Made in USA
- Limited lifetime warranty
- Power Stage 1: Air
- Stage 2: Hydraulic



MAHLE



POWER TRAIN LIFTS / TABLES

**1,250 LB. SIDE LIFT
AIR / HYD POWER
TRAIN LIFT / TABLE
#1585A**

\$2,399
FINANCE:
\$63.62 / month for
60 months

- Ideal for engine and trans-axle service
- Supports up to 1,250 lbs.
- Compact design & swivel casters for easy maneuverability
- Comes with tilting plate
- Height range: 29.5" to 68.5"



OTC



**1,250 LB. SIDE LIFT
AIR / HYD POWER
TRAIN LIFT / TABLE
#72674**

\$2,589
FINANCE:
\$68.66 / month for
60 months

- 26" - 65" Height



norco
PROFESSIONAL LIFTING EQUIPMENT

**2,500 LB. POWER TRAIN
LIFT / TABLE
#3182**

\$5,199
FINANCE:
\$120.72 / month for
60 months

- Unique safety latches at 30%, 50%, and 80% of max height
- Air assist foot pump with 9' extension
- Scissors lift design
- 8" diameter swivel casters



AFF



**2,500 LB VERTICAL LIFT,
AIR / HYD POWER T
RAIN LIFT / TABLE
#72850A**

\$5,579
FINANCE:
\$129.54 / month for
60 months

- 31" - 80" Height



norco
PROFESSIONAL LIFTING EQUIPMENT

**2,500 LB. AIR / HYD
POWER TRAIN
LIFT / TABLE
#1595A**

\$5,699
FINANCE:
\$132.33 / month for
60 months

- Scissors-type design
- Powered by an air over hydraulic foot pump
- Independent adjusting screws tilt the table 15° side-to-side, or fore-and-aft
- Large, 8" swivel casters
- Meets ASME PASE standards



**1,760 LB. VERTICAL LIFT
AIR / HYD POWER
TRAIN LIFT / TABLE
#5295**

\$7,219
FINANCE:
\$167.63 / month for
60 months

- 1,760 lb. capacity
- 36" x 42" tabletop
- 21.5" minimum height
- 70" max height



OTC

brake service

VALVE CORE TORQUE TOOL #60508

\$4⁹⁹

- Avoid damaging the TPMS sensor
- Proper torque eliminates leaking valves
- Correctly set valves prevents a false reading from the TPMS sensors



BRAKE CALIPER HANGER SET #W80624

\$7⁹⁹

- Holds brake calipers out of the way
- Helps hold exhaust systems during installation, painting small parts, & holding items while under the hood



RATCHETING BRAKE PAD SPREADER #W80110

\$49⁹⁹

- Used to compress single, twin & quad disc brake pistons on fixed & floating caliper
- Evenly spreads the force on the pistons
- Includes 2 sizes of plates
- Handle has a full 360° swing



BRAKE LATHE BITS #062-10 (AMMCO)

\$21⁹⁹

- Use on models: 1000, 1001, 3000, 4000, 4100, 7000, 7700
- Cutting edges: 6 (12 by cross-indexing)
- 10 Per package

SILENCER B&S #69 (AMMCO STYLE 6920) VENTILATED

\$24⁹⁹

- For small & large rotors
- Adjustable b& has material finish on natural rubber
- 9" Diameter 32" x 1/2"

AUTOMATIC SLACK ADJUSTER TOOL 7/16" #45020

**\$39⁹⁹
\$49⁹⁹**

9/16" #45030

- Ideal for servicing Haldex style air brakes
- 360° rotational swing for ease of operation
- Dipped handle provides comfortable non-slip grip
- Protective sleeve on drive-end keeps dirt and grime out
- Extra long handle provides increased leverage



BRAKE LATHE BITS #060-10 (ACCU-TURN)

\$47⁹⁹

- Use on models: 7700, 8901, 8922, 8944, 8989, 8991, 8893, & 8922L
- Cutting edges: 3 (6 by cross-indexing)
- 10 Per package



#80B (AMMCO STYLE 5280) DRUM

\$39⁹⁹

- Natural rubber with riveted buckle
- 6' x 1-3/4" x 1/8"



2 PIECE SLACK ADJUSTER KIT #45010

\$49⁹⁹

- Properly adjusts automatic slack adjusters on Meritor brake systems
- Includes a fork end tool for releasing the tensioner
- Includes 5/16" double square offset reversible wrench
- Thermoplastic rubber handle provides superior non-slip grip



BRAKE LATHE #RL8500

\$8,259

FINANCE:
\$191.77 / month for
60 months

- Disc/Drum/Flywheel
- Variable Feed
- 2 Speed
- Positive Rake Cutting
- Cone Kit to 4"
- 6.7/8" Spindle Travel
- Bench & Backboard



BRAKE LATHE #RL8500XL

\$8,259

FINANCE:
\$191.77 / month for
60 months

- Disc/Drum/Flywheel
- Variable Feed
- 3 Speed
- Positive Rake Cutting
- Cone Kit to 6 1/4"
- 9.7/8" Spindle Travel
- Bench & Backboard



air conditioning

MAHLE OZONEPRO + AC POWER SUPPLY #490 80003 00

- Small & portable
- iOS & android application
- Dedicated sensors for ozone level
- Sanitize the vehicle effortlessly



\$599



MAHLE

SEMI-AUTOMATIC ECONOMY R-134A MACHINE #34288NI

- Digital display & Analog gauges
- 1.5 CFM vacuum pump
- 11 lb. tank
- 1 Year warranty



\$3,869

FINANCE:
\$97.83 / month for
60 months



ROBINAIR.

Manufacturers Setup & Training Included

MID-RANGE R134A AC SERVICE SYSTEM #460 80445 00 (MODEL ARTICPRO®ACX-2150)

- Fully automatic
- 7" Capacitive touch screen
- Wi-Fi & Bluetooth
- Auto oil & dye inject
- Automatic s/w updates
- 2-Year limited warranty



\$4,099

FINANCE:
\$108.71 / month for
60 months



MAHLE

Manufacturers Setup & Training Included

PREMIER R-134A MACHINE #34788NI

- Digital display, analog gauges
- 1.5 CFM vacuum pump
- 30 lb. tank
- Oil injector
- 1 Year warranty
- Automatic



\$4,289

FINANCE:
\$113.74 / month for
60 months



ROBINAIR.

Manufacturers Setup & Training Included

MACHINE FOR HYBRID & NON-HYBRID VEHICLES #34788NI-H

- Digital display, analog gauges
- 1.5 CFM vacuum pump
- 30 lb. tank
- Oil injector
- 1 Year warranty
- Automatic



\$4,289

FINANCE:
\$113.74 / month for
60 months



ROBINAIR.

Manufacturers Setup & Training Included

ADVANCED R134A REFRIGERANT MANAGEMENT CENTER #FX134A

- Patented Oilless Compressor
- Motor-Controlled Ball Valves
- Oil Injection Kit Included
- Warranty: 1 Year Labor / 2 Years Parts / 5 Year Compressor
- Made in the USA



\$4,499

FINANCE:
\$119.31 / month for
60 months



CPS®

Manufacturers Setup & Training Included

HIGH-PERFORMANCE R134A AC SERVICE SYSTEM - HYBRID CERTIFIED #460 80448 00 (MODEL ARTICPRO®ACX- 2180H)

- Fully automatic
- 7" Capacitive touch screen
- Wi-Fi & Bluetooth
- Auto oil & dye inject
- iOS & android phone app
- Wireless printing & automatic software updates
- 2-Year limited warranty



\$4,799

FINANCE:
\$127.27 / month for
60 months



MAHLE

Manufacturers Setup & Training Included

HIGH-PERFORMANCE R134A AC SERVICE SYSTEM #460 80447 00 (MODEL ARTICPRO®ACX- 2180)

- Fully automatic
- 7" Capacitive touch screen
- Wi-Fi & Bluetooth
- Auto oil & dye inject
- iOS & android phone app
- Wireless printing & automatic software updates
- 2-Year limited warranty



\$4,799

FINANCE:
\$127.27 / month for
60 months



MAHLE

Manufacturers Setup & Training Included

**PREMIUM
R-134A
MACHINE
#34988NI**

\$4,859

FINANCE:
\$128.86 / month for
60 months

- Digital display, analog gauges
- 1.5 CFM vacuum pump
- 30 lb. tank
- Oil injector x 2
- Dye injector
- Printer
- 1 Year warranty
- Fully automatic



ROBINAIR. Manufacturers Setup & Training Included

**CONNECTED
R-134A ACS
MACHINE
#34998**

\$5,659

FINANCE:
\$131.40 / month for
60 months

- Touch screen (10")
- Analog gauges
- 1.5 CFM vacuum pump
- 30 lb. tank
- Oil injector x 2
- Dye injector
- Wi-Fi + cloud printing
- 1 Year warranty
- Fully automatic



ROBINAIR. Manufacturers Setup & Training Included

**MID-RANGE R1234YF
AC SERVICE
SYSTEM
#460 80446 00
(MODEL ARTICPRO®ACX-2250)**

\$5,899

FINANCE:
\$136.97 / month for
60 months

- Fully automatic
- 7" Capacitive touch screen
- Wi-Fi & Bluetooth
- Hybrid capable
- Refrigerant identifier with external hose
- Automatic software updates
- 2-Year limited warranty



MAHLE Manufacturers Setup & Training Included

**PREMIER
R-1234YF
RECOVERY
MACHINE
#AC1234-4**

\$6,109

FINANCE:
\$141.85 / month for
60 months

- Touch screen (4.3")
- + Analog gauges
- 1.5 CFM vacuum pump
- Refrigerant identifier
- 1 Year warranty
- Fully automatic
- Standard & hybrid



ROBINAIR. Manufacturers Setup & Training Included

**ADVANCED R1234YF
VALUE REFRIGERANT
MANAGEMENT
CENTER
#FX1234V**

\$6,499

FINANCE:
\$150.91 / month for
60 months

- Patented Oilless Compressor
- Motor-Controlled Ball Valves
- Refrigerant ID and Oil Injection Kit Included
- Warranty: 1 Year Labor / 2 Years Parts / 5 Year Compressor
- Made in the USA



cps Manufacturers Setup & Training Included

**ADVANCED R1234YF
REFRIGERANT
MANAGEMENT
CENTER
#FX1234**

\$6,999

FINANCE:
\$162.52 / month for
60 months

- Patented Oilless Compressor
- Motor-Controlled Ball Valves
- Refrigerant ID Included
- Warranty: 1 Year Labor / 2 Years Parts / 5 Year Compressor
- Made in the USA



cps Manufacturers Setup & Training Included

**HIGH PERFORMANCE
R1234YF AC SERVICE
SYSTEM
#460 80449 00
(MODEL ARTICPRO®ACX-2280)**

\$6,999

FINANCE:
\$162.52 / month for
60 months

- Ergonomic design, 7" capacitive touch screen & intuitive user interface
- iOS & android capable phone app allowing remote service session mirroring & advanced functions
- Hybrid capable
- Integrated refrigerant identifier
- Automatic software updates
- 2-Year limited warranty



MAHLE Manufacturers Setup & Training Included

**CONNECTED
R-1234YF ACS
MACHINE
#AC1234-9**

\$7,009

FINANCE:
\$162.75 / month for
60 months

- Touch screen (10")
- + Analog gauges
- 1.5 CFM vacuum pump
- Wi-Fi & cloud printing
- 1 Year warranty
- Fully automatic
- Standard & hybrid



ROBINAIR. Manufacturers Setup & Training Included

**ADVANCED R134A/R1234YF
DUAL REFRIGERANT
MANAGEMENT
CENTER
#FX3030**

\$8,669

FINANCE:
\$201.29 / month for
60 months

- Converts in 10 Minutes
- Patented Oilless Compressor
- Motor-Controlled Ball Valves
- Refrigerant ID Included
- Warranty: 1 Year Labor / 2 Years Parts / 5 Year Compressor
- Made in the USA



cps Manufacturers Setup & Training Included

AUTOMATIC 134A
#8200000
(MODEL SKR200)

\$3,599

FINANCE:
 \$95.45 / month for
 60 months

- Automatic & Manual Operation
- Watch Instructional Videos & View Manual on 8" Color Touch Screen
- WiFi built in for remote diagnostics & repair
- Vehicle Refrigerant Database included
- 6CFM Vacuum Pump
- Tank Heater Included
- Thermal Printer Optional



134A & HYBRID
#8300000
(MODEL SKR300)

\$4,099

FINANCE:
 \$108.71 / month for
 60 months

- Automatic & Manual Operation
- Watch Instructional Videos & View Manual on 8" Color Touch Screen
- WiFi built in for remote diagnostics & repair
- Vehicle Refrigerant Database included
- 6CFM Vacuum Pump
- Tank Heater Included
- Thermal Printer Included



1234YF & HYBRID
#8400000
(MODEL SKR400)

\$5,899

FINANCE:
 \$137.97 / month for
 60 months

- Automatic & Manual Operation
- Integrated Neutronics Refrigerant Identifier
- Watch Instructional Videos & View Manual on 8" Color Touch Screen
- WiFi built in for remote diagnostics & repair
- 6CFM Vacuum Pump
- Vehicle Refrigerant Database included
- Tank Heater Included
- Thermal Printer Included



ACCESSORIES

A/C & FUEL LINE DISCONNECT SET
#W83149

\$8⁹⁹

- Easily disconnects air conditioning lines & quick connect fuel lines
- Set contains 6 release tools that disengage the spring lock coupling on GM, Ford, & Chrysler fuel lines
- Disengages the spring lock coupling on Ford radiator & transmission lines



RECYCLING FILTER-DRIERS
#34724

\$79⁹⁹

- Spin-On
- Must Change Every 150 lbs. on 34788



DUST COVER FOR A/C RRR MACHINES
#17499

\$129

- AC1234, 34288NI, 34788NI, 34988NI, and 34998



R1234YF POE LABEL SYRINGE TYPE OIL INJECTOR
#18470

\$199

- Dielectric Oil for Hybrids



R1234YF NO LABEL SYRINGE TYPE OIL INJECTOR
#18460

\$209

- Sniffer Style, Mechanical Pump
- Uses AA Batteries
- 2 Year Warranty



R1234YF PAG LABEL SYRINGE TYPE OIL INJECTOR
#18465

\$219

- Sniffer Style, Mechanical Pump
- Uses AA Batteries
- 2 Year Warranty



ECONOMY REFRIGERANT LEAK DETECTOR
#LD3

\$309

- Sniffer Style
- Mechanical Pump
- Uses AA Batteries
- 2 Year Warranty
- Works with 134a & 1234yf



SELECT REFRIGERANT LEAK DETECTOR
#LD5

\$429

- Mechanical Pump
- Uses AA Batteries
- Color LCD Display
- UV Light
- 2 Year Warranty
- Works with 134a & 1234yf



diagnostic



MAXISYS ADVANCED DIAGNOSTIC WIRELESS TABLET + BLUETOOTH #MS906S

\$1,199

FINANCE:
\$31.80 / month for
60 months

- 8-inch Wireless Touchscreen
- Compatible with U.S., Asian & European Vehicles, 1996+
- Bluetooth VCI Mini for easier OBDII port connection
- Android 4.4, Hexa-core Processor, 64 GB Memory
- Flint Lighter, T-Grade Hose, Cutting Tip #0

MAXIIM KEY PROGRAMMING TABLET #IM508

\$1,499

FINANCE:
\$39.75 / month for
60 months

- 7" Touchscreen Android Tablet
- Powerful Key Programming & IMMO Functionality
- All Systems Vehicle Diagnostics
- Comprehensive Service Menu
- Includes the XP200 Key & Chip Programming

MAXISYS MS906PRO DIAGNOSTIC TABLET #MS906PRO

\$1,799

FINANCE:
\$47.71 / month for
60 months

- Advanced diagnostic tablet compatible with U.S., Asian and European vehicle, 1996 and newer
- Octa-Core Processor / 128 GB memory / 4 GB RAM
- Performs all system scan with ADAS identification / Customizable Pre & Post scans
- Read/Erase Codes, View Freeze Frame and Live Data
- Welding Tip #0 Check Valves



MAXISYS MS906PRO-TS DIAGNOSTIC TABLET #MS906PROTS

\$2,099

FINANCE:
\$55.67 / month for
60 months

- Advanced diagnostic tablet compatible with U.S., Asian and European vehicle, 1996 and newer
- Complete TPMS servicing: Activate/read all known sensors, diagnose system, program 1-Sensor, relearn sensors
- 8-inch Wireless Touchscreen tablet with embedded antenna, Bluetooth-enabled MaxiSYS VCI200
- Bi-directional control capability including Active test/Performs coding and adaptations

MAXISYS COMPLETE FOR COMMERCIAL VEHICLES #MS908CV

\$3,299

FINANCE:
\$87.49 / month for
60 months

- Class 1- 9 Commercial Vehicles, SAE J1939, SAE J1708
- MFG. CUST. J1939/J1708 Protocols
- AutoVIN: 2006+, AutoSCAN: All Modules in All Systems
- 25 Service Functions, Bi-Directional Control
- Includes: J2534 MaxiFlash Elite Pass-Thru Programming Device

MAXISYS DIAGNOSTIC TABLET #MS909

\$3,799

FINANCE:
\$100.75 / month for
60 months

- 9.7" Touchscreen (1536 x 2048), Android 7.0
- 2.3GHz+1.7GHz Octa-core Processor, 128GB Memory
- New VCI Protocols: D-PDU, DoIP/CAN FD, Mega CAN
- Topology Module Mapping: Color Coded All System Status Screen (on supported vehicles)
- Relevant Cases: DTC Troubleshooting, Repair Tips

AUTEL



MAXIIM IMMO AND KEY PROGRAMMING BUNDLE
#IM608PROKPA

\$3,999

FINANCE:
\$106.05 / month for 60 months

- Includes: MaxiIM IM608 10.1" Android Tablet
- Includes: XP400Pro Key and Chip Programmer
- Includes: JVIC Wireless J2534 Pass through Programming Device
- Includes: IMKPA Key Programming Adapter Kit
- Program IMMO & Keys for U.S., Asian & More European Vehicles

MAXISYS DIAGNOSTIC TABLET
#MS919

\$4,749

FINANCE:
\$125.94 / month for 60 months

- 9.7" Touchscreen (1536 x 2048), Android 7.0
- 2.3GHz+1.7GHz Octa-core Processor, 128GB Memory
- Advanced VCMI 5-In-1 Device: VCI, Oscilloscope, Multimeter, Waveform Generator, CAN BUS Check
- Topology Module Mapping: Color Coded All System Status Screen (on supported vehicles)
- Relevant Cases: DTC Troubleshooting, Repair Tips

MAXISYS ADVANCED DIAGNOSTIC TABLET
#MSULTRA

\$5,699

FINANCE:
\$132.33 / month for 60 months

- Large 12.9" Touchscreen (2732 x 2048), Android 7.0
- 2.3GHz + 1.7GHz Octa-core Processor, 256G Memory
- Advanced VCMI 5-In-1 Device: VCI, Oscilloscope, Multimeter, Waveform Generator, CAN BUS Check
- Split Screen Multi-Application Function, Topology Module Mapping (on supported vehicles)
- Relevant Cases: DTC Troubleshooting, Repair Tips



AUTEL



LAUNCH X431 OSCILLOSCOPE MODULE 4 CHANNEL LAB SCOPE
#301180831

\$899

- 4 channel Oscilloscope
- Add on module for x431 Throttle, Pad 2
- Analyze waveforms, variety of faults on sensors, actuators, circuits, and electronic control units
- Record, compare, & examine waveforms based on parameters
- Parameters include amplitude, pulse width, and array

LAUNCH X431 TORQUE 3 PROFESSIONAL DIAGNOSTIC TABLET
#301190720

\$1,499

FINANCE:
\$39.75 / month for 60 months

- Android 9.0 custom operating system
- Octocore CPU 1.8Ghz, 3GB RAM, 32GB ROM, 32GB SD Card
- 7000 mAh internal battery, WIFI, Bluetooth
- 10.1" touchscreen 1920 x 1200 FHD IPS
- Front 5.0 MP camera, Rear 8.0 rear camera

LAUNCH X431 THROTTLE PROFESSIONAL DIAGNOSTIC TABLET
#301180595

\$2,599

FINANCE:
\$68.93 / month for 60 months

- Android 7.1 custom operating system, WIFI, Bluetooth
- Qualcomm 8 core processor, QC 3.0 quick charge technology
- IP65 protection, front 8 MP camera, rear 13 MP camera
- Wide Coverage of vehicle models, strong diagnostic functions
- Supports extension modules, Battery, Scope, Ignition, Multimeter, Sensor Box

LAUNCH



CAN OBDII DIAGNOSTIC SCAN TOOL
#W2977

\$39⁹⁹

- Works with most 1996 & later models
- Supports all OBD2 protocols including Controller Area Network
- Reads your (DTC) Diagnostic Trouble Codes for identification
- Turns off check engine light (MIL)
- Erases (DTC) trouble codes & resets the OBDII system

AUTOLINK ENGINE CODE READER
#AL329

\$39⁹⁹

- Covers Domestic, Asian & European Vehicles (1996+)
- Read/ Erase Engine DTCs
- One-Touch I/M Readiness, LED Indicator
- Display Live & Freeze Frame Data
- FREE Lifetime Software (lifetime of tool) & 1Year Warranty

AUTOLINK ADVANCED ENGINE CODE READER
#AL529

\$99⁹⁹

- Read/ Erase DTCs for Engine
- Read Enhanced Powertrain Codes on GM/Ford/Chrysler
- One-Touch I/M Readiness, LED Indicator
- Tests: O2 Monitor, On-Board Monitor, and Oxygen Sensor
- FREE Lifetime Software (lifetime of tool) & 1Year Warranty



AUTEL

ONE IS ENOUGH

D-PDU / RP1210 / DOIP / CAN FD

CODE ASSIST BY IDENTIFIX

TOPOLOGY MAPPING FUNCTION



PASSENGER CARS & HEAVY DUTY VEHICLES



X-431 Throttle III

10 COMPATIBLE MODULES



\$4,999

X-431 Throttle III



\$2,599

X-431 Throttle



\$1,499

X-431 Turbo III



\$1,499

X-431 Turbo

CONFIGURATION

| | | | | |
|-----------------------------|-----------------------|-----------------------|-----------------------------|-----------------------------|
| Touch Screen | 13.3" / 1920x1080 IPS | 10.1" / 1920x1200 IPS | 10.1" / 1920x1200 IPS | 8" / 1280x800 IPS |
| Processor | 2.0GHz Octa-core | 2.0GHz Octa-core | 1.8GHz Octa-core | 2.0GHz Quad-core |
| Memory/Storage | 8GB / 256GB | 4GB / 64GB | 3GB / 32GB + 32GB (SD Card) | 3GB / 32GB + 32GB (SD Card) |
| Camera | Front 8MP, Rear 13MP | Front 8MP, Rear 13MP | Front 5MP, Rear 8MP | Front 2MP, Rear 5MP |
| Battery | 9360mAh X2 | 9360mAh | 7000mAh | 5000mAh |
| VCI Connection/ VCI Adaptor | Smartlink / Wi-Fi | DBScar VI / Bluetooth | DBScar VI / Bluetooth | DBScar VI / Bluetooth |
| Non-16pin Connector Kits | ● | ● | ● | |
| IP65 Waterproof & Dustproof | ● | ● | | |

FEATURES

| | | | | |
|---------------------------|--|--|--|-----------------------------|
| Vehicle Coverage | 1996-Present Passenger cars Heavy, Medium & Light Duty Vehicles | 1996-Present Passenger cars Heavy, Medium & Light Duty Vehicles | 1996-Present Passenger cars Heavy, Medium & Light Duty Vehicles | 1996-Present Passenger cars |
| Operating System | Android™ 9.0 | Android™ 7.1 | Android™ 9.0 | Android™ 9.0 |
| Remote Diagnosis | ● | ● | ● | ● |
| Auto VIN Identification | ● | ● | ● | ● |
| Security Gateway Access | ● | ● | ● | ● |
| Code Assist by IDENTIFIX | ● | ● | ● | ● |
| VW & AUDI Guided Function | ● | ● | ● | |
| CAN FD/DoIP/RP1210/D-PDU | ● | CAN FD (Optional) | CAN FD (Optional) | CAN FD (Optional) |
| O2-1 Scope Box | ● | ● | | |

2.7" LCD INSPECTION CAMERA
#W50045

\$119

- 2.4" color LCD monitor with 320 x 240 VGA resolution & 180 degree image rotation & mirroring
- Submersible 11/32" (9mm) diameter camera with 640 x 480 resolution
- 4 white LEDs with 6 output levels

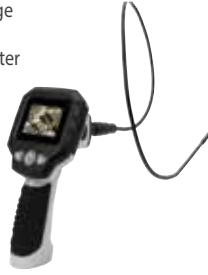

MILLENNIUM 70 PRO
#301050574

\$119

- Multipurpose code reader
- OBD2/EOBD diagnostic functions
- Read and clear DTC's and live data stream for 3 systems (ABS, SRS, and Auto Transmission)
- Choose 3 service functions from the 10 most common
- Features 3.5-inch color display capable of 4 graphs



LAUNCH

AUTOLINK 4 SYSTEM CODE READER
#AL629

\$179

- Read/ Erase DTCs for ABS, SRS, Engine & Transmission
- AutoVIN: 2006+, Manufacturer-Specific Codes
- Tests: O2 Monitor, On-Board Monitor & O2 Sensor
- I/M Readiness, Emissions Testing
- FREE Lifetime Software (lifetime of tool) & 1Year Warranty



AUTEL

MILLENNIUM 90
#301050345

\$199

- Tests 6 & 12-Volt Batteries - Including Flooded & AGM
- GRX-3000 test the battery while charging the battery, monitoring continuously to determine battery status
- Easy to use with little or no training
- Charging Voltage: Up to 17 volts, .1 resolution
- Charging Current: 0-50 Amps, 1 Amp resolution



MILLENNIUM 90 PRO
#301050365

\$219

- 4.0" TFT 320x480 DPI screen
- Multipurpose code reader that provides 10 OBD2/EOBD diagnostic modes
- Oil reset, brake bleeding, EPB, BMS, DPF, SAS reset
- Live data stream, read Engine, Auto Transmission, ABS & SRS



CRP ELITE
#301050451

\$299

- Android 7.0, 1.0Ghz quad core processor, 1GB memory, 8GB storage
- 5" color capacitive touch screen
- Supports all 10 modes of OBD2, and able to diagnose 4 main systems (engine, transmission, ABS, SRS)
- Reset functions, EPB, SAS, DPF, Oil Light, ABS Bleeding
- Generate and share diagnostic reports via email



MILLENNIUM MASTER
#301050455

\$299

- Android 7.0, 1.0Ghz quad core processor, 1GB memory, 8GB storage
- 4000 mAh lithium ion battery
- Supports TPMS relearn database, injector relearn and immobilizer resets



GEAR SCAN PLUS
#301050458

\$389

- 7" High Resolution IPS capacitive touch screen
- 4000 mAh lithium ion battery, 1.3Ghz quad-core CPU
- Android 7.0, Gear+ future community functions
- Extensive vehicle coverage with 10 OBD2 test modules



MILLENNIUM HD PRO
#301050372

\$419

- 4.0" LCD screen
- For gasoline vehicles, read and clear DTCs
- For heavy duty vehicles (J1708 and J1939) read and clear DTC's and data stream
- Supports resend command for most makes and models
- Includes 6 pin, Type 2 9 Pin, & 16 pin adapters



LAUNCH

MAXICHECK MX808 ADVANCED SERVICE + ALL SYSTEMS DIAGNOSTICS
#MX808

\$499

- 7" Touchscreen, 1.5GHz Quad-Core Processor, 32GB Memory, 2GB RAM
- Android 4.4.4, 1Year FREE Wi-Fi Software Updates
- AutoVIN: 2006+, AutoSCAN: All Modules in All Systems
- 17 Service Functions, Generates Printable Diagnostic Reports
- Covers Domestic, Asian & European Vehicle (1996+)



ROXIE-W
#301050450

\$699

- Android 7.1, 6000mAh lithium ion battery
- 5" touch screen, 8GB built in storage
- Auto scans all makes, models, & modules then email pre/post scan reports (up to 5 emails at a time)
- WIFI enabled, easy to operate
- Sleek industrial design, enhanced all module scan



GEAR HD
#301050388

\$1,799

FINANCE:
\$47.71 / month for 60 months

- 5" 720P IPS touch screen, Android 7.0, 4000 mAh battery
- System detect diagnosis and manual diagnosis
- HD OBD diagnoses: 10 Modes of OBD tests are supported
- Tests include EVAP, O2 sensor, I/M Readiness, MIL status, VIN info, and on-board motors testing
- Diagnostic history and feedback functions



AUTEL

HD3 ADD-ON MODULE
#301190246

\$2,599
FINANCE:
\$68.93 / month for
60 months

- Diagnose Heavy & Medium Duty Trucks (Class 4 through 8)
- Turns Launch x-431 Throttle into Heavy Duty truck scan tool
- Bluetooth or hardwire to 12V or 24V
- Special functions: Component replacement, Cylinder Compression tests, Injector Cut out tests & DPF regeneration
- Supports engine, transmissions, ABS, and auxiliary by Wabco, Bendix, and Allison



LAUNCH

X-431 TORQUE AUTOHD
#301190748

\$3,499
FINANCE:
\$92.79 / month for
60 months

- 10.1" 1920x1200 FHD screen, 7000mAh battery
- Android 9.0, Octocore 1.8Ghz, 3GB RAM + 32GB storage
- Extensive coverage of Asian, Euro, and Domestic Automotive
- Heavy Duty capability with the HD3 module that is included
- Code Assist, Auto VIN Scan, Remote Tech 2 Tech



LAUNCH X431 THROTTLE 3
#301180833

\$4,999
FINANCE:
\$132.57 / month for
60 months

- Android 9.0, quad core 2.0 Ghz processor, 3GB memory
- Now capable of Carline and HD applications
- 13.3" IPS touch screen 1920x1080, 9360 mAh battery
- Code Assist fix database, Tech 2 tech remote diagnosis
- ADAS, SGW, Vin Scan, bidirectional, Scope & Sensor box compatible



ADAS

MAXISYS INTELLIGENT ADAS OPTICAL POSITIONING SYSTEM
#IA800

\$4,999
FINANCE:
\$132.47 / month for
60 months

- Includes 6 hi-res cameras, wheel clamps, targets, & power supply
- Do away with mechanical measurements
- Significantly reduce setup time and increase positioning accuracy
- Ideal for collision repair, glass replacement, and repair shops
- Fast, accurate, and infinitely repeatable
- Check alignment tolerances prior to calibration
- Check alignment tolerances prior



MAXISYS ADAS CALIBRATION MA600 LDW 2.0 PACKAGE
#MA60020

\$12,349
FINANCE:
\$280.12 / month for
60 months

- Perform Vehicle LDW Camera Calibrations
- Collapsible Aluminum Calibration Frame
- Includes 2-Line Centering and 5-Line Alignment Lasers



MAXISYS ADAS CALIBRATION ALL SYSTEMS 2.0 PACKAGE
#MAS20

\$23,359
FINANCE:
\$530.25 / month for
60 months



MAXISYS ADAS CALIBRATION ALL SYSTEMS 2.0 PACKAGE
#AS20

\$30,939
FINANCE:
\$673.15 / month for
60 months

- Includes ADAS Software Upgrade & DIGITALADAS add-on
- LDW Patterns / Targets for Alpha Romeo, Honda, VW, Mercedes, Hyundai / Kia, Nissan, Infiniti, Mazda, Mitsubishi, Mazda, Subaru, Toyota / Lexus
- Night Vision Calibrator package for VW, Mercedes, GM
- Lidar Calibration for VW / Audi, Lexus, Toyota
- AVM patterns / systems for Hyundai / Kia, Nissan, Mitsubishi, Toyota, VW, Honda, GM
- RCW patterns/package for VW, Nissan, Mercedes
- Expansion pack for RCW, AVM, LIDAR, and NV system calibrations
- One-year limited warranty

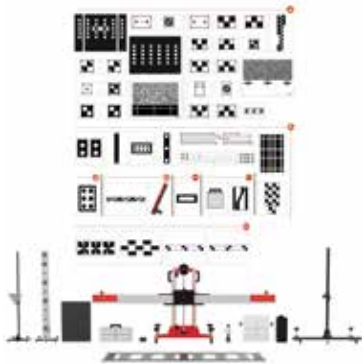

AUTEL

LEAK TESTERS

READYSMOKE™ LEAK TESTER
#95-0400

\$799

- Includes flow meter
- Flow control valve & leak down gauge
- Fluid & accessories



REDLINE
DETECTION
www.redlinedetection.com

SMOKE PRO® TOTAL TECH® LEAK TESTER
#95-0003C

\$1,149
FINANCE:
\$30.47 / month for
60 months

- Includes flow meter
- Flow control valve & leak down gauge



LEAKTAMER EVAP SYSTEM
#6522

\$1,129
FINANCE:
\$29.94 / month for
60 months

- OEM approved (leak tamer)



OTC



AUTEL® MAXISYS™

ADAS

ADVANCED DRIVER ASSISTANCE SYSTEM

CALIBRATION FOR CAMERA, RADAR & NIGHT VISION-BASED SYSTEMS. FOR COLLISION, GLASS REPLACEMENT & SPECIALTY REPAIR SHOPS.



STANDARD FRAME

The Autel MaxiSYS ADAS Standard Frame is ideal for one-location shops or for use with an Alignment Machine. The sturdy, adjustable frame provides a new station to bring ADAS Calibration services in-house.

\$5,009

FINANCE:
\$116.10 / month for
60 months

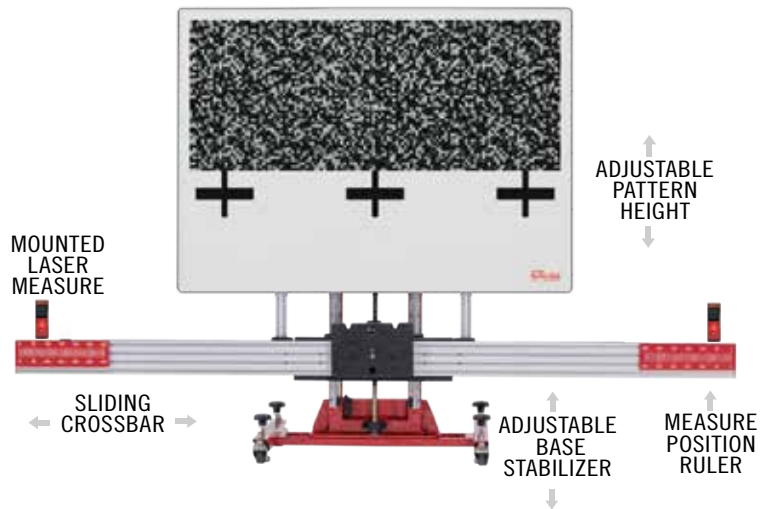

MA600 FRAME

The Autel MaxiSYS ADAS MA600 Frame is ideal for multi-location shops. The compact frame, folds and disassembles to easily fit into the trunk of a car or service truck.

\$5,219

FINANCE:
\$121.09 / month for
60 months

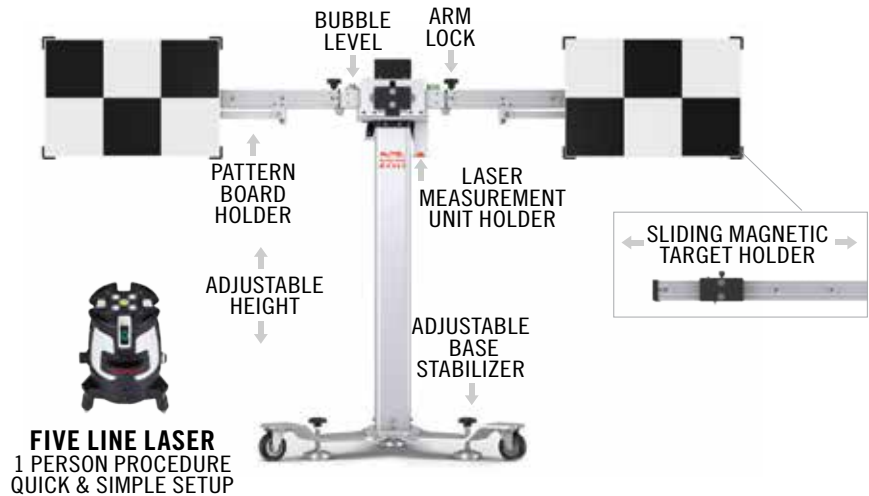

CHECK OUT AUTEL'S ADAS CALIBRATION FRAMES IN THE DIAGNOSTIC CATEGORY OF THIS ISSUE!



TEL: 1.855.288.3587 | WEB: AUTEL.COM
EMAIL: USSUPPORT@AUTEL.COM AUTEL.COM
FOLLOW US @AUTELTOOLS



SCAN TO WATCH
TRAINING
VIDEOS
YouTube



AUTEL®

©2021 Autel U.S. Inc., All Rights Reserved

battery service

BST-360 BLUETOOTH ENABLED BATTERY TESTER #301180832

\$119

- Apps on Android & IOS store
- Monitor battery health status
- Anti-heat characteristics and prevention against backfire
- Syncs with smartphones, tablets, and professional Launch diagnostic scan tool



12V BATTERY/ ELECTRICAL SYSTEM TESTER #PBT-300

\$249

- Conductance
- 12V
- 100-1400 CCA
- 18" Cables with standard metal clamps



6V / 12V BATTERY TESTER #MDX-640

\$479

- Digital Battery Analyzer
- Conductance
- 6 & 12V
- Tests Conventional, AGM & Gel Batteries
- 4' Cables with Standard Metal Clamps (A207)



LAUNCH

12V BATTERY & ELECTRICAL SYSTEM TESTER #MDX-P300

\$549

- Conductance
- 12V
- Integrated Printer
- 18" Cables with Standard Clamps



HD/FLEET 6/12V BAT, 12/24V ELECTRICAL SYSTEM TESTER #MDX-700 HD

\$649

- Conductance
- 12V
- Integrated Printer
- 18" Cables with Standard Clamp



6V/12V BATTERY, 12/24V ELECTRICAL TESTER + PRINTER #MDX-650P SOH

\$699

- Conductance
- 6 & 12V
- SOH Graph
- Integrated Printer
- Tests Conventional, AGM, Gel & EFB Batteries
- 10' Cables w/Large Plastic Clamps (A315)
- Protective Rubber Boot
- Tool Bag (A156)



POWER SUPPLY CHARGERS

2M CABLES #MSP-070-2 \$749

3M CABLES #MSP-070-3 \$799

5M CABLES #MSP-070-5 \$849

- Provides clean, reliable power for charging & battery maintenance
- Select voltages of 13.2, 13.6, & 14.4 VDC
- Charges Flooded lead acid, AGM, & EFB chemistry's
- Output: 14.4 VDC; 70A maximum
- Integrated carry handle



BATTERY & ELECTRICAL 12V/24V SYSTEM ANALYZER #CPX-900

\$899

- Conductance & Conductance Profiling Technology
- Identify batteries with poor reserve capacity & cranking health
- Test 6V & 12V Flooded, EFB, AGM & Gel batteries
- Email test results directly from tool
- Infrared temperature sensor
- Ergonomic shape, size and grip



BATTERY DIAGNOSTICS STATION #GRX-3000

\$1,299

FINANCE:
\$34.45 / month for
60 months

- Tests 6V & 12V Batteries, Including Regular Flooded And AGM Batteries
- GRX-3000 test the battery while charging the battery, monitoring continuously to determine battery status
- Easy to use with little or no training
- Charging Voltage: Up to 17 volts, .1 resolution
- Charging Current: 0-50 Amps, 1 Amp resolution



MIDTRONICS

AUTEL® MAXIBAS BATTERY & ELECTRICAL SYSTEM ANALYZERS

BT608

TAKE CHARGE

INTELLIGENT BATTERY SERVICE

POWERED BY
AUTEL
DIAGNOSTICS

\$479



ADAPTIVE LOAD & CONDUCTANCE



BMS RESET FUNCTIONALITY



SYSTEM DETECTION

BATTERY & ELECTRICAL SYSTEM DIAGNOSTICS

- 5.5" Touchscreen / Android 9.0 / Wi-Fi Software Updates
- Test 6 & 12 Volt Batteries: 100 - 3000 CCA
- Test 12 & 24 Volt Cranking / Charging Systems

FASTER VEHICLE ID: AUTOVIN & VINSCAN

- Battery Specific System & Location Confirmation
- Test Battery / Charging System for Proper Function
- Electrical System Reset

AUTEL® MAXIBAS

\$199



BT506

\$299



BT508

\$799



BT609



TEL: 1.855.288.3587 | WEB: AUTEL.COM
 EMAIL: USSUPPORT@AUTEL.COM AUTEL.COM
 FOLLOW US @AUTELTOOLS



SCAN TO WATCH
TRAINING VIDEOS
 YouTube



AUTEL®

©2021 Autel U.S. Inc., All Rights Reserved

BATTERY CHARGERS



2 AMP ULTRASAFE SMART BATTERY CHARGER #GENIUS2

\$69⁹⁹

- 6V/12V Battery charger/maintainer
- Charges lead-acid & lithium-ion batteries up to 40 amp-hours
- Spark-proof technology & reverse polarity protection
- Auto desulfation, auto detection & auto repair
- Charge down to zero volts



5 AMP ULTRASAFE SMART BATTERY CHARGER #GENIUS5

\$89⁹⁹

- 6V/12V Battery charger/maintainer
- Charges lead-acid & lithium-ion batteries up to 120 amp-hours
- Spark-proof technology & reverse polarity protection
- Auto desulfation, auto detection & auto repair
- Charge down to zero volts



10 AMP ULTRASAFE SMART BATTERY CHARGER #GENIUS10

\$119

- 6V/12V Battery charger/maintainer
- Charges lead-acid & lithium-ion batteries up to 230 amp-hours
- Spark-proof technology & reverse polarity protection
- Auto desulfation, auto detection & auto repair
- Charge down to zero volts

JUMP STARTERS



500-AMP BOOST SPORT ULTRASAFE LITHIUM JUMP STARTER #GB20

\$99⁹⁹

- Recommended for engines up to 4.0L Gas for cars, boats, motorcycles, trucks, ATVs, + more
- Mistake-proof and safe for anyone to use with spark-proof technology and reverse polarity protection
- Safely jump start a dead battery in seconds - up to 20 times on a single charge



1,000-AMP 12V LITHIUM GENIUS BOOST & JUMP STARTER #GB40

\$119

- Ultra-safe, ultra-compact, rugged, and portable lithium-ion
- Spark proof technology and reverse polarity protection
- Instantly jump starts most single-battery applications, up to 20 times on a single charge
- Ideal for engines up to 6.0L gas and 3.0L diesel
- Recharge virtually any USB device
- Includes ultra-bright dual LED flashlight with 7 modes, including SOS and emergency strobe



1,500-AMP ULTRASAFE LITHIUM JUMP STARTER #GB50

\$199

- Spark-proof connections & reverse polarity protection
- Recharges USB devices
- Power 12V devices anywhere, like tire inflators, power inverters, etc.
- 400 lumen LED flashlight with multiple modes, including SOS
- Jump starts gas engines up to 7 liters & diesel engines up to 4.5 liters



2,000-AMP ULTRASAFE LITHIUM JUMP STARTER #GB70

\$249

- Spark-proof connections & reverse polarity protection
- Power 12V devices anywhere & recharge USB devices
- 400 lumen LED flashlight with multiple modes, including SOS
- Jump starts gas engines up to 8L & diesel engines up to 6L



3,000-AMP ULTRASAFE LITHIUM JUMP STARTER #GB150

\$349

- Spark-proof connections & reverse polarity protection
- Power 12V devices anywhere & recharge USB devices
- 500 Lumen LED flashlight with multiple modes, including SOS
- Jump starts gas engines up to 9.0L & diesel engines up to 7.0L
- Provides up to 80 jump starts on a single charge



6,250 AMP 12V/24V ULTRASAFE LITHIUM JUMP STARTER #GB500

\$1,799

FINANCE:
\$47.71 / month for
60 months

- Compact, 12V and 24V, rated at 20,000 Amps, 80,000 Joules 3S
- Includes a high-intensity 2,200 lumen LED work light with 7 light modes, including SOS and Emergency Strobe
- Dual USB ports to recharge multiple devices, over 20 smartphone recharges
- Designed for both gas & diesel engines up to Class 8+ / CE high-displacement vehicles, equipment, trucks

NOCO

battery service



REMOVE BATTERY CLEANER
#E404

\$6⁹⁹

- Instantly neutralizes, dissolves & removes battery corrosion
- Ideal for battery terminals, cables, hold-downs & boxes
- Restores maximum current flow
- Reduces potential voltage leakage
- Packaged in a 14-ounce aerosol can



NCP2 CORROSION SPRAY
#A202

\$12⁹⁹

- Stops battery corrosion for the life of your battery
- Oil-based formula that does not dry or evaporate
- Environmentally safe & resistant to reversion, moisture, shock & vibration
- The original formula since 1914 & made in the USA



BATTERY BOX

- Locking tabs fasten cover securely to the case
- Impact & UV resistant + heavy-duty carrying handles
- Fully ventilated to release battery gases safely
- Meets Coast Guard (USCG) Code of Federal Regulations 183.420 & American Boat and Yacht Council (ABYC) E-10.7
- Suitable for start-stop & CANbus vehicle systems



6-VOLT SNAP-TOP
#HM306BK

\$12⁹⁹

- Designed for a single 6 volt battery

GROUP 24 31 SNAP-TOP
#HM318BK

\$12⁹⁹

- Designed for a single group 24 to group 31 battery

GROUP 24 SNAP-TOP
#HM300BKS

\$12⁹⁹

- Designed for a single group 24 battery



EVA PROTECTION CASE

- Lightweight, durable, & rugged custom exterior
- Equipped with a zipper closure & reinforced handle for storing & carrying boost
- Offers protection from moisture, impact, dust, & environmental factors
- Additional pockets for related Boost accessories (sold separately)



BOOST XL
#GBC017

\$29⁹⁹

- Fits the NOCO GB50 Boost UltraSafe Jump Starters (sold separately)

BOOST HD
#GBC014

\$39⁹⁹

- Fits the NOCO GB70 Boost UltraSafe Jump Starters (sold separately)

BOOST PRO
#GBC015

\$39⁹⁹

- Fits the NOCO GB150 Boost UltraSafe Jump Starters (sold separately)



shop equipment

FANS

JETSTREAM™ 220 PORTABLE EVAPORATIVE COOLER #PACJS2201A1

\$699

- Cools 700 sq. ft.; 2,400 CFM; 20 gallon reservoir
- Equipped with Kuul Comfort MicroTech™ evaporative media, the highest-quality evaporative media available & made in the USA exclusively for Portacool products
- Oscillating louvers help cool a larger area
- Liquid level indicator with automatic pump shutoff protects your product & investment
- Lifetime warranty on evaporative cooler housing against manufacturing defects & three year warranty on all electrical components



JETSTREAM™ 230 PORTABLE EVAPORATIVE COOLER #PACJS2301A1

\$1,149

FINANCE:
\$30.47 / month for
60 months

- Cools 900 sq. ft.; 3,600 CFM; 30 gallon reservoir
- Equipped with Kuul Comfort MicroTech™ evaporative media, the highest-quality evaporative media available & made in the USA exclusively for Portacool products
- Oscillating louvers help cool a larger area
- Liquid level indicator with automatic pump shutoff protects your product & investment
- Lifetime warranty on evaporative cooler housing against manufacturing defects & three year warranty on all electrical components



JETSTREAM™ 250 PORTABLE EVAPORATIVE COOLER #PACJS2501A1

\$2,499

FINANCE:
\$66.27 / month for
60 months

- Cools 2,125 sq. ft.; 8,500 CFM; 55 gallon reservoir
- Equipped with KUUL Comfort MicroTech™ evaporative media, the highest-quality evaporative media available & made in the USA exclusively for Portacool products
- This energy efficient cooling solution requires the same energy of a small standard household appliance
- Liquid level indicator with automatic pump shutoff protects your product & investment
- Lifetime warranty on evaporative cooler housing against manufacturing defects & three year warranty on all electrical components



JETSTREAM™ 260 PORTABLE EVAPORATIVE COOLER #PACJS2601A1

\$3,149

FINANCE:
\$83.51 / month for
60 months

- Cools 3,125 sq. ft.; 12,500 CFM; 60 gallon reservoir
- Equipped with KUUL Comfort MicroTech™ evaporative media, the highest-quality evaporative media available & made in the USA exclusively for Portacool products
- This efficient evaporative cooler uses approximately the same amps as a standard wet/dry vacuum
- Liquid level indicator with automatic pump shutoff protects your product & investment
- Lifetime warranty on evaporative cooler housing against manufacturing defects & three year warranty on all electrical components



JETSTREAM™ 270 PORTABLE EVAPORATIVE COOLER #PACJS2701A1

\$4,299

FINANCE:
\$114.01 / month for
60 months

- Cools 5,625 sq. ft.; 22,500 CFM; 65 gallon reservoir
- Equipped with KUUL Comfort MicroTech™ evaporative media, the highest-quality evaporative media available & made in the USA exclusively for Portacool products
- Whole-shop cooling at a fraction of the operating cost of traditional air conditioning
- Liquid level indicator with automatic pump shutoff protects your product & investment
- Lifetime warranty on evaporative cooler housing against manufacturing defects & three year warranty on all electrical components



PORTACOOOL™

PARTS WASHERS & SPRAY WASH CABINETS

20-GALLON PARTS WASHER #31200B

\$309

- 12 Gallon working capacity
- 50 GPH pump output
- Removable work shelf and parts basket
- Flexible nozzle gets parts cleaner
- Heavy duty steel construction



40-GALLON PARTS WASHER #31400B

\$549

- 22 Gallon working capacity
- 50 GPH pump output
- Removable work shelf and parts basket
- Flexible nozzle gets parts cleaner
- Heavy duty steel construction



SPRAY WASH CABINET #RS-500D-601

\$6,849

FINANCE: \$159.03 / month for 60 months

- 30" Turntable
- 45" Working Height
- 500lb Load 50 Gallon Tank
- 1HP / 70gpm Pump, Dual Heaters, Low Water Shutoff, Includes Parts Tree, Small Basket & 20lb Soap (230V-1PH)



SPRAY WASH CABINET #RS-750D-601

\$6,849

FINANCE: \$159.03 / month for 60 months

- 30" Turntable
- 54" Working Height
- 1000lb Load
- 53 Gallon Tank
- 1HP / 70gpm Pump, Dual Heaters, Low Water Shutoff, Includes Parts Tree, Small Basket & 20lb Soap (230V-1PH)



SPRAY WASH CABINET #RS-500DS-601

\$9,369

FINANCE: \$217.55 / month for 60 months

- Stainless Steel Cabinet
- 30" Turntable
- 45" Working Height
- 500lb Load 50 Gallon Tank
- 1HP / 70gpm Pump, Dual Heaters, Low Water Shutoff, Includes Parts Tree, Small Basket & 20lb Soap (230V-1PH)



SPRAY WASH CABINET #RS-750DS-601

\$9,369

FINANCE: \$217.55 / month for 60 months

- Stainless Steel Cabinet
- 30" Turntable
- 54" Working Height
- 1000lb Load
- 53Gallon Tank
- 1HP / 70gpm Pump, Dual Heaters, Low Water Shutoff, Includes Parts Tree, Small Basket & 20lb Soap (230V-1PH)



PRESSURE WASHERS

COLD WATER ALUMINUM FRAME #225CS-020000

\$919

- Made in America
- 2.5 GPM @ 2000 PSI
- GC160 Honda
- Gas engine



COLD WATER 1,500 PSI #I215C-000000

\$1,409

FINANCE: \$37.37 / month for 60 months

- Made in America
- 2 GPM @ 1500 PSI
- 115V
- 2 HP electric



COLD WATER 4,000 PSI DIRECT DRIVE GX390 HONDA GAS ENGINE #445CS-020000

\$1,759

FINANCE: \$46.65 / month for 60 months

- 4 GPM @ 4000 PSI
- Lightweight and corrosion resistant
- FREE: industrial hose with swivel end and bend restrictor, professional-grade insulated trigger gun with safety lock, insulated wand, and quick connect nozzle



HOT WATER 1,500 PSI #I215AD-000000

\$4,019

FINANCE: \$106.58 / month for 60 months

- Made in America
- 2 GPM @ 1500 PSI
- 115V, 20 Amp
- Diesel fired 115V burner
- Industrial duty triplex pump



GENERATORS

2,000 WATT DUAL FUEL INVERTER WITH PARALINK #200959

call for special pricing

- 39 pounds, 53 dBA from 23 feet
- Gasoline: 2,000 starting & 1,700 running watts, up to 11.5 hours run time
- Propane: 1,530 running watts, up to 34 hours
- Includes: (2) covered 120V 20A household outlets, (2) USB
- 3-year limited warranty + FREE lifetime technical support



3,500 WATT DUAL FUEL OPEN FRAME INVERTER #200977

call for special pricing

- 3-year limited warranty with FREE lifetime technical support
- 50% quieter (64dBA) and 20% lighter than a traditional 3500-watt generator + fuel-saving Economy Mode, Intelligauge to monitor voltage, frequency & operating hours
- Produces 4250 starting watts and 3500 running watts on gasoline with a 22-hour run time and 4250 starting watts and 3150 running watts on propane with a run time of 21 hours



4,500 WATT INVERTER WITH PARALINK #200989

call for special pricing

- EZ Start Dial, Cold Start Technology, Extended Run Time, and an easy to read fuel gauge
- 0.5-quart oil capacity (included 10W-30) + low oil shut-off sensor
- Ultra-quiet 61 dBA from 23'
- Includes: (1)120V 30A RV, (2) 120V 20A house-hold outlets, (2) USB ports
- 3-year limited warranty with FREE lifetime technical support



3,500-WATT RV READY PORTABLE GENERATOR + REMOTE START #200964

call for special pricing

- Includes wireless remote key fob with 80-foot reach
- 3-way ignition switch + built-in Cold Start Technology
- 68 dBA from 23 feet; 4,375 starting & 3,500 running watts
- Includes: (1) 120V 30A locking, (1) 120V 30A RV, (2) 120V 20A outlets & Volt Guard™, Wheel Kit, Battery, Engine Oil & Oil Funnel
- 3-year limited warranty with FREE lifetime technical support



3,500-WATT DUAL FUEL + ELECTRIC START #200966

call for special pricing

- Includes a battery + Cold Start Technology
- Gasoline: 4,375 starting & 3,500 running watts, up to 14 hours run time
- Propane: 3,150 running watts, up to 10.5 hours
- Includes: (1) 120V 30A locking, (1) 120V 30A, (1) 120V 20A duplex, Propane Hose, Wheel Kit, Generator Cover, Engine Oil & Oil Funnel
- 3-year limited warranty with FREE lifetime technical support



5,000-WATT + 25' POWER CORD #201041

call for special pricing

- Includes 1.2-quarts of oil & low oil shut-off sensor
- 439cc Champion engine, battery included
- Gasoline: 9,375 starting watts and 7,500 running watts
- Propane: 8,400 starting watts and 6,750 running watts
- 3-year limited warranty with FREE lifetime technical support



7,500-WATT DUAL FUEL PORTABLE GENERATOR + ELECTRIC START #201040

call for special pricing

- At 6,250 starting watts and 5,000 running watts, enjoy up to 9 hours of run time on a full tank of gasoline with a noise level of 74 dBA from 23 feet
- (1) 120/240V 30A locking outlet and (4) 120V 20A GFCI outlets
- Includes 3-year limited warranty with FREE lifetime technical support



12,000-WATT + ELECTRIC START & LIFT HOOK #100111

call for special pricing

- Up to 9 hours of run time, 78 dBA from 23 feet
- 717cc V-Twin Champion engine with battery-included electric start & built-in Cold Start Technology
- Includes: (1)120V 30A locking, (1) 120/240V 30A locking, (1)120/240V 50A, (4) 120V 20A GFCI outlets & Volt Guard™
- 3-year limited warranty with FREE lifetime technical support



1,200-1,500-WATT PORTABLE GENERATOR STORAGE COVER #C90015

call for special pricing

- This cover is designed for 1,200-1,500-watt generators, but will also fit generators up to 18.9 x 15.8 x 14.2-inches in size
- Protect your generator from sun and UV damage, rain, snow, dirt and more with tough vinyl exterior
- Strong elastic base provides a secure, custom-like fit
- Includes 1-year limited warranty



3,000-4,000-WATT PORTABLE GENERATOR STORAGE COVER #C90011

call for special pricing

- This cover is designed for 3,000-4,000-watt generators, but will also fit generators up to 25 x 23.6 x 20.3-inches in size
- Protect your generator from sun and UV damage, rain, snow, dirt and more with tough vinyl exterior
- Strong elastic base provides a secure, custom-like fit
- Includes 1-year limited warranty



5,000-9,000-WATT PORTABLE GENERATOR STORAGE COVER #C90016

call for special pricing

- This cover is designed for 5,000-9,500-watt generators, but will also fit generators up to 30.7 x 23.6 x 23.6-inches in size
- Protect your generator from sun and UV damage, rain, snow, dirt and more with tough vinyl exterior
- Strong elastic base provides a secure, custom-like fit
- Includes 1-year limited warranty



2,000W-3,000 WATT INVERTER PARALLEL CABLE KIT #100740

call for special pricing

- Parallel kit sits on top of inverter for easy access to the standard 120V 30A (TT-30R) RV outlet and 120V 30A locking outlet (L5-30R)
- Includes a 30-amp circuit breaker to prevent overloads
- Seamlessly integrates any two 2000-watt to 3000-watt ParalINK ready inverters with a hand-tightened clamp for easy attachment
- Includes 1-year limited warranty with FREE lifetime technical support



OIL FILTER CRUSHERS

HEAVY-DUTY FLOOR STAND #FS-300

\$479

- AFC-100-94 & HDC-150-94
- Accommodates 16-gal. drum
- 23"W x 23"D x 36"H



OIL FILTER CRUSHER #RP-20FC

\$1,799

FINANCE: \$47.71 / month for 60 months

- Automotive
- 10 Ton
- 9"H x 6"D Filter Size
- Includes RP-20FCS Floor Stand No Charge (5-55 Gallon)



PNEUMATIC OIL FILTER CRUSHERS #8203, MODEL C-4

\$2,459

FINANCE: \$65.21 / month for 60 months

- Reduces filters by 75% of original size
- Removes 95% of the free-flowing oil so it can be recycled
- C-4 crushing chamber accepts filters 7.5" tall x 5" diameter
- Safety door: crusher will not operate if door is opened
- Lifetime warranty on housing, 1-year limited on all other parts
- 12" Flexible drain hose
- Cycle time: 5-7 seconds
- Air requirement: 125-175 PSI



FREE STAND WITH PURCHASE

OIL FILTER CRUSHERS AUTOMOTIVE #AFC-100-94

\$2,709

FINANCE: \$71.84 / month for 60 months

- Max filter height 13"
- 15-Ton crushing force
- Air/hydraulic operation
- Door channel prevents drips and leakage
- Requires air filter/regulator/lubricator (not included)



PNEUMATIC OIL FILTER CRUSHERS #7610, MODEL C-6

\$2,919

FINANCE: \$77.41 / month for 60 months

- Reduces filters by 75% of original size
- Removes 95% of the free-flowing oil so it can be recycled
- C-4 crushing chamber accepts filters 7.5" tall x 5" diameter
- C-6 crushing chamber accepts filters up to 10" tall x 7" diameter
- Safety door: crusher will not operate if door is opened
- Lifetime warranty on housing, 1-year limited on all other parts
- 12" Flexible drain hose
- Cycle time: 5-7 seconds
- Air requirement: 125-175 PSI



FREE STAND WITH PURCHASE



OIL FILTER CRUSHERS HEAVY-DUTY TRUCK #HDC-150-94

\$3,499

FINANCE: \$92.79 / month for 60 months

- Max filter height 13"
- 15-Ton crushing force
- Air/hydraulic operation
- Door channel prevents drips and leakage
- Requires air filter/regulator/lubricator (not included)



PNEUMATIC HEAVY-DUTY OIL FILTER CRUSHER #8210 (MODEL TT12)

- For tractor trailer & truck filters
- Reduces filters by 75% of original size
- Removes 95% of the free-flowing oil so it can be recycled
- Safety door—crusher will not operate if door is opened
- Cycle time: 23 seconds
- Accepts filters up to 17"
- Air requirement: 145 to 175 PSI
- All parts in contact with air are rust proof
- Lifetime warranty on housing, 1-year limited on all other parts



\$5,519

FINANCE:
\$128.15 / month for
60 months



MADE IN THE USA

PNEUMATIC OIL FILTER CRUSHERS #7720 (MODEL TT25-EH)

- Reduces filters by 75% of original size
- Removes 95% of the free-flowing oil so it can be recycled
- C-4 crushing chamber accepts filters 7.5" tall x 5" diameter
- C-6 crushing chamber accepts filters up to 10" tall x 7" diameter
- Safety door: crusher will not operate if door is opened
- Lifetime warranty on housing, 1-year limited on all other parts
- 12" Flexible drain hose
- Cycle time: 5-7 seconds
- Air requirement: 125-175 PSI



\$7,079

FINANCE:
\$164.37 / month for
60 months



FREE STAND WITH PURCHASE

WASTE OIL HEATERS

XT-75 HEATER 6" ROOF CHIMNEY #XT-75

\$4,029

FINANCE:
\$106.85 / month for
60 months

- Heats up to 1,700 sq. ft. and up to 75,000 BTU
- Pre-assembled for easy installation



XT-150 WASTE OIL HEATER #XT-150

\$6,439

FINANCE:
\$149.51 / month for
60 months

- Heats up to 3,500 sq. ft. and up to 150,000 BTU
- Comes standard with an easy access hinged chamber door for easy clean out
- Burns 100% used synthetic oil



XT-200 WASTE OIL HEATER #XT-200

\$7,029

FINANCE:
\$163.21 / month for
60 months

- Heats up to 5,000 sq. ft and up to 200,000 BTU
- Comes standard with an easy access hinged chamber door for easy clean out
- Burns 100% used synthetic oil



XT-250 WASTE OIL HEATER #XT-250

\$8,219

FINANCE:
\$190.85 / month for
60 months

- Heats up to 8,500 sq. ft. and 250,000 BTU
- Comes standard with an easy access hinged chamber door for easy clean out
- Burns 100% used synthetic oil



XT-300 WASTE OIL HEATER #XT-300

\$8,729

FINANCE:
\$202.69 / month for
60 months

- Heats up to 10,000 sq. ft. and up to 300,000 BTU
- Comes standard with an easy access hinged chamber door for easy clean out
- Burns 100% used synthetic oil



HEADLIGHT AIMERS

VISUAL OPTICAL HEADLIGHT AIMER #1010000 (MODEL SCA 1)

\$899

- Revolutionary ISO color technology takes the guesswork out of headlamp alignment
- Durable & lightweight
- Adjustable height
- Laser floor slope measurement is accurate & easy to achieve
- Field calibration
- Accurate & repeatable alignment
- Compact & portable
- Non-electric
- Rotational mast allows for easy alignment of optical head to vehicle

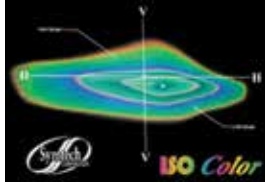

DIGITAL CAMERA HEADLIGHT AIMER #6010000 (MODEL DVA 6)

\$2,899

FINANCE:
\$76.88 / month for
60 months

- Aligns all lamp patterns: SAE, VOR, VOL, Euro
- Aligns all lamp types: Halogen, Xenon, HID, LED
- LCD Color touch screen
- Multi-language: English, French & Spanish
- Line laser vehicle alignment
- Laser centering on headlamp
- Laser floor slope measurement
- Multi-bay usage & floor-slope recording
- Rechargeable battery operated
- RS232, Ethernet, Wi-Fi, Bluetooth capable
- Optional printer available
- 1-Year warranty



MADE IN THE USA

STRUT COMPRESSORS

STRUT SPRING COMPRESSOR #7600

\$979

- Ship by dim weight (44x18x20)
- Known as "the standard in the industry," the 7600 handles the heaviest coil-over-shocks, on light trucks and SUV's, without needing additional adapters
- It also has longer handles for extra torque
- The multi-positions upper spring hooks can be arranged for ultimate flexibility to fit "factory" coil spring configurations



STRUT COMPRESSOR & FLOOR STAND #6637-ST

\$1,199

FINANCE:
\$31.80 / month for
60 months

- Meets new ASME PASE safety standards & capable of safely compressing the largest strut springs
- Provides quick and safe strut service for technicians
- Includes the Strut Tamer II Extreme & stand with wheels
- Strongest compression force on the market - up to 4,000 pounds to compress and rebuild



VICE TOOLS

3" CLAMP-ON VISE #W3900

\$219

- Portable design quickly clamps to any work surface up to 1-1/2" thick
- Twin steel guide bars & built-in pipe jaws
- 2-3/8" Jaw opening & 1-5/8" throat depth
- Durable powder-coat finish & chrome-plated hardware



8" MACHINIST VISE #MV8

\$279⁹⁹

- 360° Swivel base with 3 mounting holes & 2 lock downs
- 7" Jaw opening & 3" throat depth
- Polished built-in anvil: 4-1/4" x 4"
- Durable powder-coat finish & chrome-plated hardware



5" QUICK RELEASE BENCH VISE #W3904

\$149

- Save time & effort when positioning the movable jaw
- Pull the quick release lever & the movable jaw slides in & out with ease
- 360° Swivel base with 3 mounting holes & 2 lock downs
- Features steel replaceable pipe jaws for holding pipe or round stock
- 7" Jaw opening & 3" throat depth
- Polished built-in anvil: 2-11/64" x 1-7/8"



6" GENERAL DUTY SWIVEL BENCH VISE #3942

\$209

- Replaceable hardened steel serrated jaws
- Built in pipe jaws 3-1/2" capacity
- 6" Maximum opening
- 3.5" Throat depth



8" GENERAL DUTY SWIVEL BENCH VISE #3943

\$319

- Replaceable hardened steel serrated jaws
- Built in pipe jaws 3-1/2" capacity
- 8" Maximum opening
- 4" Throat depth
- Large anvil surface



BENCH GRINDERS

6" BENCH GRINDER #W5001

\$99⁹⁹

- Equipped with work light
- 1/2 HP Motor
- 3,400 RPM
- 1/2" Arbor
- 36 Grit & 60 grit wheels



8" BENCH GRINDER #W50058

\$109

- Versatile & compact unit supplied with 36 & 60 grit grinding wheels
- 3/4 HP UL approved @ 115V, 60Hz & 3,450 RPM
- Wide & clear eye shields
- Adjustable tool rests
- Ball bearings for durability
- Cast-iron housing



6" BENCH GRINDER #31510

\$159

- 6" Grinder
- 1/2 HP Ball bearing motor 120V, 2.8 Amp 60 Hz
- 1/2" Arbor
- 3/4" Wheel Width
- Cast aluminum base



BENCH-TOP DRILL PRESS #W50005

\$179

- 1/3 HP, 5-speed
- For drilling household metal, plastic & wood
- 1/2" Spring loaded chuck with protective guard
- Machined table tilts 45° left & right
- Cast-iron construction
- CSA Approved
- 1/2" Spring-loaded chuck with protective guard & 2-1/2" vise



8" BENCH GRINDER #31520

\$199

- 8" Grinder
- 3/4 HP Ball bearing motor 120V, 4.8 Amp 60 Hz
- 5/8" Arbor
- 1" Wheel Width
- Cast aluminum base



42" HDPE CREEPER - 440 LB
#57100

- Low-profile design
- 100% high density polyurethane (HDPE) material will not warp or bend
- Carrying handle
- Oil, grease and chemical resistant casters



\$149

1,750 LBS WORK BENCH
#RWB-2D

- 59" x 25"
- 1 Shelf & 2 Drawers



\$889

1,750 LBS WORK BENCH
#RWB-2S

- 79" x 25"
- 2 Shelves



\$949

500-LB TEAR TOWN TABLE
#RWB-1TD

- 48" 28"
- Fluid catch
- 1 Drawer



\$959



SUPER DUTY SHOP PRESS

- Fully welded construction for exceptional strength and durability
- Double pump air motor for faster speeds
- Glycerin filled gauge accurately shows pressing force
- Shatter resistant polycarbonate shield for maximum protection
- Available in 30, 50, 75, 100, & 150 ton Models

20-TON
#850ASD

\$1,999

FINANCE:
\$53.01 / month for 60 months

30-TON
#852ASD

\$2,999

FINANCE:
\$79.53 / month for 60 months

50-TON
#854ASD

\$4,499

FINANCE:
\$119.31 / month for 60 months

75-TON
#856ASD

\$5,999

FINANCE:
\$139.30 / month for 60 months

100-TON
#859ASD

\$8,499

FINANCE:
\$197.35 / month for 60 months

150-TON
#862ASD

\$13,999

FINANCE:
\$317.78 / month for 60 months



welding

EASY WELD 100 STICK WELDER #298

\$279

- Stick / TIG (Requires TIG Torch #85657)
- 120 Volts Input / 90 Amps Output
- Welds Up to 1/4"
- Uses 1/16" - 3/32" Electrodes
- Inverter Power Source
- 10' Electrode Cable & Clamp, 10' Ground Cable & Clamp, 6' Power Cable
- 1-Year Warranty
- Weight: 14 lbs



EASY WELD 140 FC-I FLUX-CORE WELDER #261

\$299

- Gasless / Flux-Core Welding Only
- 120 Volts Input / 140 Amps Output
- Welds Up to 1/4"
- Uses .030" FC Wire
- Inverter Power Source
- 8' MIG Gun, 8' Ground Cable & Clamp, 6' Power Cable
- 1-Year Warranty
- Weight: 19 lbs



EASY WELD 20 P PLASMA CUTTER #251

\$499

- 120V Input / 20 Amps Output
- Cuts up to 1/4" Mild Steel & up to 1/8" Aluminum
- Inverter Power Source
- 13' Plasma Torch, 8' Ground Cable & Clamp, 6' Power Cable
- 1-Year Warranty
- Weight: 22 lbs



EASY WELD 140 MP MIG MULTI-PROCESS WELDER #271

\$519

- MIG / Flux-Core / Stick / TIG* (Requires TIG Torch #85657)
- Gas / Gasless Welding
- 120 Volts Input / 140 Amps Output
- Welds Up to 1/4"; Uses .030" Wire
- Inverter Power Source
- 10' MIG Gun, 10' Electrode Cable & Clamp 8' Ground Cable & Clamp, 6' Power Cable
- 1-Year Warranty
- Weight: 22 lbs



140 MIG WELDER #309

\$699

- 120 Volts Input / 140 Amps Output
- Welds Up to 1/4" Mild Steel
- Regulator and Gas Hose Included
- MIG (Gas) and Flux Cored Welding
- 10' MIG Torch, 10' Ground Cable & Clamp, 15' Power Cable
- Transformer Welder
- Full 3-Year Warranty
- Weight: 63 lbs



180 MIG WELDER #318

\$899

- 230 Volts Input / 190 Amps Output
- Welds Up to 3/8" Mild Steel
- Regulator and Gas Hose Included
- MIG (Gas) and Flux Cored Welding
- 10' MIG Torch, 10' Ground Cable & Clamp, 15' Power Cable
- Transformer Welder
- Full 3-Year Warranty
- Weight: 57 lbs



40 P PLASMA CUTTER #440

\$1,499

FINANCE:
\$39.75 / month for
60 months

- 240 / 120 Volts Input / 40 Amps Output
- Cut 5/8" Mild Steel & 3/8" Aluminum
- Spare Consumables included
- 20' IPT 40 Plasma Torch, 15' Ground Cable & Clamp, 15' Power Cable
- Full 3-Year Warranty
- Weight: 30 lbs



220 MP MULTI-PROCESS WELDER #410

\$1,529

FINANCE:
\$34.71 / month for
60 months

- MIG, TIG, Stick Welder (Requires TIG Torch #85660)
- Welds Up to 1/2" Mild Steel
- Flow Meter Regulator and Hose Included
- MIG (Gas) and Flux Cored Welding
- 12.5' 200A PRO Grip MIG Gun, 15' Electrode Holder, 15' Ground Cable & Clamp, 15' Power Cable, 240V to 120V Adapter
- Inverter Welder
- Full 3-Year Warranty
- Weight: 51 lbs



Forney

5 LBS. E7018 1/8" STICK ELECTRODE #30805

\$16⁹⁹

- Low Hydrogen
- High Strength
- High Quality on Mild Steel
- All-Position, DC



5 LBS. E6013 1/8" STICK ELECTRODE #30405

\$16⁹⁹

- General Purpose on Light-Gauge Mild Steel or Sheet Metal
- All-Position, AC or DC



5 LBS. E6011 1/8" STICK ELECTRODE #31205

\$16⁹⁹

- Deep Penetration on Rusty, Dirty, Painted Mild Steel
- All-Position, AC or DC+



2 LB .030" FLUX-CORE WELDING WIRE #42300

\$19⁹⁹



2 LB .035" FLUX-CORE WELDING WIRE #42302

\$19⁹⁹



33 LB .035" 70S-6 STEEL MIG WELDING WIRE #42281

\$89⁹⁹



LEATHER WELDING GLOVE SIZE LARGE #53422

\$19⁹⁹

- Heat & abrasion resistant
- Reinforced patches in key areas
- Extremely durable with Kevlar stitching for extra strength



SIGNATURE WELDING GLOVE SIZE LARGE #53410

\$39⁹⁹

- Heat & abrasion resistant
- Reinforced patches in key areas
- Our most comfortable and durable with Kevlar stitching for extra strength



SHOP FLAME MEDIUM-DUTY TORCH KIT #1705

\$229

- For Oxygen-Acetylene Cutting, Welding, Heating
- Cuts Up to 6"; Welds Up to 3/8"
- Built-In Check Valves
- Includes 20' T-Grade Hose, Goggles & Striker



EASY WELD "BLACK" ADF WELDING HELMET #55731

\$49⁹⁹

- Lightweight, Impact Resistant
- Quick-fit, 5-Point Adjustable headgear with Sweatband
- 5.97 Sq. Inch Viewing Area
- 9 to 13 Variable Shade
- 1/25,000 Switching Speed
- Two Optical Arc Sensors
- Battery Backup



EASY WELD "VELOCITY" ADF WELDING HELMET #55732

\$49⁹⁹

- Lightweight, Impact Resistant
- Quick-fit, 5-Point Adjustable headgear with Sweatband
- 5.97 Sq. Inch Viewing Area
- 9 to 13 Variable Shade
- 1/25,000 Switching Speed
- Two Optical Arc Sensors
- Battery Backup



FORNEY "BLACK" ADF WELDING HELMET #55857

\$59⁹⁹

- Lightweight, Impact Resistant
- Quick-fit, 5-Point Adjustable headgear with Sweatband
- 5.97 Sq. Inch Viewing Area
- 9 to 13 Variable Shade
- 1/25,000 Switching Speed
- Two Optical Arc Sensors
- Battery Backup



FORNEY "SCORTCH" ADF WELDING HELMET #55859

\$89⁹⁹

- Lightweight, Impact Resistant
- Quick-fit, 5-Point Adjustable headgear with Sweatband
- 5.97 Sq. Inch Viewing Area
- 9 to 13 Variable Shade
- 1/25,000 Switching Speed
- Two Optical Arc Sensors
- Battery Backup



FORNEY "CAMO" PRO ADF WELDING HELMET #55936

\$139

- Lightweight, Impact Resistant
- Quick-fit, 5-Point Adjustable headgear with Sweatband
- 10.44 Sq. Inch Viewing Area
- HD Optical Clarity
- 5 to 13 Variable Shade
- 1/25,000 Switching Speed
- Four Optical Arc Sensors
- Battery Backup



FORNEY "WARHAWK" PRO ADF WELDING HELMET #55938

\$189

- Lightweight, Impact Resistant
- Quick-fit, 5-Point Adjustable headgear with Sweatband
- 10.44 Sq. Inch Viewing Area
- HD Optical Clarity
- 5 to 13 Variable Shade
- 1/25,000 Switching Speed
- Four Optical Arc Sensors
- Battery Backup



JACKSON®

SAFETY

All-New Premium Welding Helmets from Jackson Safety®

Introducing the all-new premium auto-darkening helmets from Jackson Safety®. The offering includes 6 styles featuring bold new graphics that will keep users looking sharp while performing at their best. The helmets offer best-in-class optical clarity, top-notch switching speeds and exceptional ergonomic design, all for between \$99 - \$209 full MSRP.



47101
\$169.00



47104
\$129.00



47105
\$149.00



47103
\$179.00



47100
\$119.00



47102
\$99.99

370
SPEED DIAL™

- Unique Graphics
 - 6 Feet Under (47100)
 - Hellfire (47101)
 - Reapers n' Roses (47104)
 - Gray Matter (47102)
 - Bead Demon (47105)
 - Freedom (47103)
- Auto Darkening
- Super Lightweight
- Exclusive 370 Speed Dial™ Headgear

A / Une / Una

SureWerx™

Brand / Marque / Marca

SureWerx USA Inc., Elgin, IL 60123
surewerx.com/usa

fluid & grease handling

EXCHANGERS, EXTRACTORS & EVACUATORS

0.5-GALLON PNEUMATIC BRAKE FLUID EXCHANGER #JDI-050EV

\$99⁹⁹

- Clean and simple brake bleeding
- Compressed air/venturi vacuum operation
- Heavy-Duty polyethylene construction
- Muffler for quiet operation
- Convenient carry handle
- Evacuates a variety of other fluids from vehicles or small engines



1.7-GALLON MANUAL FLUID EXTRACTOR #JDI-172EV

\$109

- Portable & versatile
- Includes extractor tubes
- Hand Pump Activated vacuum operation
- Sliding foot pedal for stability
- Automatic stop to prevent overflow



2.7-GALLON PNEUMATIC FLUID EXTRACTOR #JDI-277EV

\$149

- Efficiently extract a wide range of fluids from tanks and reservoirs
- Includes extractor tubes
- Compressed air/venturi vacuum operation
- Heavy-duty polyethylene construction



2.3-GALLON MANUAL FLUID EVACUATOR & DISPENSER #MV7201

\$119

- 2.3 gal (8.8 l) Reservoir capacity
- Manual operation
- Brake bleeding with MVA7205



2.3-GALLON PNEUMATIC FLUID EVACUATOR #MV7300

\$119

- Air operation
- Brake bleeding



PNEUMATIC BRAKE BLEEDER & FLUID DISPENSER #MV7135

\$219

- Utilizes compressed "shop-air" to produce vacuum for extracting and pressure for dispensing
- Includes accessories for extracting used brake fluid while refilling with new



PNEUMATIC ATF FLUID DISPENSER KIT #MV7412

\$299

- Utilizes compressed "shop-air" to produce pressure for fluid dispensing
- Includes adapters for most modern sealed transmissions
- Conveniently located ON/OFF and flow control valve



MANUAL PRESSURE BRAKE BLEEDER #MV6840

\$349

- Pushes new fluid down through the master cylinder to flush air and old fluid out through the bleed screws
- Conveniently located ON/OFF and flow control valve
- One-man operation



**POWER STEERING
FLUID EXCHANGER**
#33010000 (MODEL PSE1)

\$1,099

FINANCE:
\$29.15 / month for
60 months

- Portable & lightweight
- 12v operation
- Electronic handheld control for precise fluid control
- 5 Quart new & used fluid tanks
- Options: with cart, with cart and rechargeable 12v power system, additional new fluid tanks



**DIFFERENTIAL
FLUID EXCHANGER**
#32010000 (MODEL DFE1)

\$1,999

FINANCE:
\$53.01 / month for
60 months

- Electronic handheld control for precise fluid control
- 5 Quart new & used fluid tanks
- Air actuated, high volume pump for viscous gear oils
- Includes custom steel cart with on-board rechargeable 12v battery with charger
- Options: additional new fluid tanks



**DUAL MODE COOLANT
FLUID EXCHANGER**
#35010000 (MODEL VFX1)

\$2,599

FINANCE:
\$68.93 / month for
60 months

- Dual-mode functionality—in-line back flush or vacuum drain-n-fill
- Time saving efficiency—vacuum elimination of airlocks
- Multi-fluid tank exchange
- 2 Interchangeable new fluid tanks
- 15-Gallon used fluid tank
- Easy to follow color-coded operation with quick-reference guide
- High-efficiency “engine off” flush
- Pressure check/vacuum test
- All adapters included



**DUAL MODE TRANSMISSION
FLUID EXCHANGER**
#30140000 (MODEL ATF4)

\$3,699

FINANCE:
\$98.10 / month for
60 months

- Cooler line & dipstick service
- Measures in 0.1 Qt increments
- Never needs recalibration
- 32qt new & used tanks
- Can be used with heavy-duty vehicles
- 3 Pumps eliminates internal fluid cross-contamination
- Adapters included



OIL SERVICE

**8-GALLON PLASTIC
OIL DRAIN**
#3508

\$109

- Portable plastic fluid waste drain with 36"-65" adjustable funnel
- Integrated oil filter drain shelf for convenience, eliminating the need for a secondary surface to drain filter or set tools



**18-GALLON
OIL DRAIN**
#3601

\$279

- Pressurized 18 gallon portable fluid drain tank with 14" bowl
- Accepts standard shop air up to 150 psi; includes combo evacuation hose/sight gauge



**18-GALLON SELF-EVAC
OIL DRAIN**
#JDI-18DC

\$349

- Offers a pressure relief safety valve to prevent over pressurizing the tank, & four 3 inch chemical resistant casters
- 18-gallon steel tank
- Height adjustments from 36-1/2" to 59"
- Pressure relief safety valve
- Reinforced 16" deep drawn 'centered' funnel



6-GALLON FLUID EVACUATOR
#JDI-6EV

\$379

- Easy-to-read vacuum generator
- Six suction probes for most applications
- 7 Inch wheels for easy handling
- Three 'OE style' evacuator adapters
- Sight tube for quick indication of fluid level



JD JohnDow
Automotive Service Equipment

18-GALLON WASTE OIL DRAIN + PRESSURIZED EVACUATION
#8893

\$449

- 6' wire reinforced drain hose
- Tank mounted oil level sight gauge
- Preset pressure regulator
- Standard 14" x 5" deep drain funnel
- Heavy duty wheels and casters



POLY 22-GALLON A/F DRAIN
#JDI-22DCAF

\$629

- Built-in filter drain
- Pop-up fluid level indicator
- 3" access port
- Padded handle bars
- Convenient drain valve adapts to most quick disconnect couplers



17-GALLON LOW-PROFILE OIL DRAIN
#JDI-LP4

\$639

- 10" ground clearance
- Easily converts to self-evac drain with air evacuation kit (sold separately)
- Expanded metal shield
- Long-reach T-Handle



AIR EVACUATION KIT
#JDI-EK

\$209

- 7 PSI fixed regulator
- Safety relief valve
- 10' evacuation hose & 2" drain plug



25-GALLON HD SELF-EVAC OIL DRAIN
#JDI-25HDC

\$649

- "Top Of The Line" - Designed and built with superior quality and performance in mind
- Auto-Check Technology for easy, automatic drain evacuation
- Sight glass gives a quick indication of fluid level
- Molded poly tool tray
- 4-caster design
- Chemical & oil resistant casters
- 16" funnel with expanded metal screen



10-GALLON LOW PROFILE A/F DRAIN WITH PUMP
#JDI-AF10E

\$849

- 110V electric pump for easy evacuation
- 10' quick disconnect evacuation hose
- 5" ground clearance
- All steel construction
- Long reach T- Handle



JD JohnDow
Automotive Service Equipment

24-GALLON WASTE OIL DRAIN + PRESSURIZED EVACUATION
#8890

\$899

- 6' drain hose
- 15-3/4" drain funnel and wide 24" adapter
- Tank mounted oil level sight gauge
- Convenient tool tray for parts and accessories
- Heavy duty wheels for effortless transport



ACCESSORIES

RUBBERIZED TOOL TRAY #JDI-RT1

\$15⁹⁹

- 14 3/4" L x 6 1/4" H x 1" D
- Molded rubber to conform to different surfaces
- Skid-reducing



JohnDow
Automotive Service Equipment

2-PACK OIL DRAIN SPLASH PADS #JDI-SP1

\$20⁹⁹

- Tight weaves eliminates splatter or splashing
- Fits standard oil drain pans with trimming ease for perfect fitment



ALUMINUM HEAVY DUTY LEVER #W54290

\$25⁹⁹

- Extremely lightweight aluminum anodized barrel + Zinc plated lever with a PVC grip
- Extra heavy T-handle + internal return spring
- 3-way loading
- Accepts standard 14oz cartridge
- 4 jaw coupler with protective PVC cap, lever handle style with PVC grips



PT
Performance Tool

ALUMINUM HEAVY DUTY PISTOL GRIP #W54291

\$29⁹⁹

- 3-way loading, accepts standard 14oz cartridge
- 4 jaw coupler with protective PVC cap
- Textured rubber non-slip barrel grip
- Extremely lightweight aluminum anodized barrel
- Pistol grip style with PVC grips



AUTOMOTIVE TEST KIT + PLASTIC PUMP #MV8000

\$44⁹⁹

- Engine performance diagnostics, brake bleeding, fluid transfer, evacuation, sampling, windshield repair and more



JohnDow
Freight Included

mityvac

POWERSTEERING ADAPTER KIT #MVA670

\$59⁹⁹

- Use with the MV8500 or MV8000
- Brake bleeding, Pressure
- Clutch bleeding, Pressure
- Each adapter is designed to fit snugly in the neck of the power steering reservoir to form an air-tight seal when vacuum is applied



JohnDow
Freight Included

AUTOMOTIVE TEST KIT + METAL PUMP #MV8500

\$79⁹⁹

- Provides vacuum or pressure with equal precision and convenience



JohnDow
Freight Included

SPRAY WASHER & COOLING SYSTEM FLUSHER #MV7270

\$99⁹⁹

- Combines water with compressed air to quickly and effectively flush cooling systems
- Stepped-up flushing nozzle fits hoses from 3/4-inch to 2-inch in diameter
- Variable-control water valve enables adjustment of water from off to full flow



JohnDow
Freight Included

12V LITHIUM-ION POWERLUBER #1262

\$219

- Lithium-ion battery for maximum power and efficiency
- Cordless lubrication for operator convenience



12V LITHIUM-ION POWERLUBER + 2 BATTERIES #1264

\$269

- 3-Point base keeps tool upright and stable
- Light weight and comfortable grip reduces fatigue and makes lubricating easier
- Delivers up to 8,000 PSI to easily bust through dirty or clogged grease fittings



20V LI-ION POWERLUBER KIT HIGH-OUTPUT + 2 BATTERIES #1888

\$379

- Two-speed transmission delivers 3.5 oz / min in low-output position and 10 oz / min in high-output position
- Includes 2 extra grease couplers and a battery energy gauge to identify battery level
- High-torque motor develops up to 10,000 psi pressure



20V LI-ION POWERLUBER KIT HIGH-OUTPUT #1886

\$299

- Two-speed transmission delivers 3.5 oz / min in low-output position and 10 oz / min in high-output position
- LED indicators identify loss of prime, empty cartridge or blocked fittings
- Sturdy 3-point base allows gun to stay upright to keep out contaminants



20V LITHIUM-ION POWERLUBER KIT #1882

\$319

- Stable 3-point stance keeps the tool upright and within reach
- Electronically controlled two-speed motor



20V LI-ION POWERLUBER KIT + 2 BATTERIES #1884

\$399

- Stable 3-point stance keeps tool upright & within reach
- LCD identifies: Empty Cartridge, Loss of Prime, Grease Output, Blocked fitting
- Lithium Technology, Powerful, Efficient & Long-Lasting



LINCOLN



FARM TANK FUELING HOSES

- Designed for durability & flexibility
- Oil & abrasion resistant
- Supplied with static wire
- Recommended for use with electric pumps
- Engineered for dispensing gasoline, kerosene & oil from farm & barrel-type pumps where UL approval is not required

#FT012S10R (3/4" X 10') **\$23⁹⁹**

#FT016S10R (1" X 10') **\$34⁹⁹**

#FT012S20R (3/4" X 20') **\$39⁹⁹**

#FT016S20R (1" X 20') **\$59⁹⁹**



MULTI-PLANE SWIVEL

- Compatible with unleaded, diesel, & Ethanol blends through E10
- Compact & light weight for easy handling
- High flow rates due to laminar flow design
- High-strength step shoulder bearing diameters & impact absorbing stops

#000350R (3/4" M X 3/4" F) **\$38⁹⁹**

#000087R (1" M X 1" F) **\$67⁹⁹**



ADJUSTABLE JARHEAD

- Only mechanical tank gauge that is adjustable by the customer
- Allen wrenches included to adjust & tighten linkages
- Infinitely adjustable within size ranges 32" – 48"
- Durable glass housing
- Highly visible orange indicator
- 2" NPT Threads

#009918R **\$95⁹⁹**

XFS UNLEADED NOZZLE
#337004NR-02

\$89⁹⁹

- Automatic shut-off nozzle for farm
- 12V skid tanks & consumer pump applications
- Strong, improved flow up to 18-GPM & 68.1-LPM
- Equipped with a unique Flo-Stop® device that shuts off the nozzle if it falls from the fill tank or raises above the horizontal position
- Not for use with gravity tanks
- Comes with 3-notch hold open clip, full grip guard & hanging hook



UNLEADED NOZZLE
#045704NR-02

\$99⁹⁹

- 1GS Nozzle shuts off when the gas tank is full
- Equipped with unique Flo-Stop® device that shuts off the nozzle if it falls from the Tank or raises above the horizontal position
- Not for use with gravity tanks
- Not legal for retail dispensing applications
- Also includes 3-notch hold open clip & hook



HEAVY-DUTY DIESEL NOZZLE
#045710NR-03

\$99⁹⁹

- 1GS Nozzle shuts off when the gas tank is full
- Equipped with unique Flo-Stop® device that shuts off the nozzle if it falls from the tank or raises above the horizontal position
- Not for use with gravity tanks
- Not legal for retail dispensing applications
- Also includes 3-notch hold open clip & hook



HEAVY-DUTY DIESEL VIII NOZZLE
#173310NR-03

\$159

- VIII Nozzle shuts off when the gas tank is full
- Spout is reinforced with thick aluminum bushing that retains spout spring & keeps spout from rounding-in
- Equipped with unique Flo-Stop® device that shuts off the nozzle if it falls from the tank or raises above the horizontal position
- Also includes 3-notch hold open clip, waffle splash guard & spout bushing

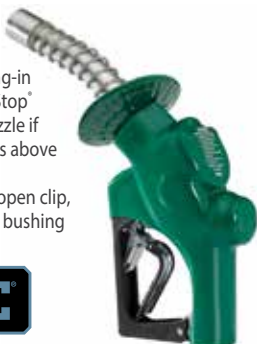

RED FOX® LIQUID LEVEL GAUGE
#007665R

\$209

- 1 Gauge accommodates tanks up to 99"
- Large number display
- Direct drive
- 2" NPT Thread
- Nickel-plated brass chain
- Oversized floats with swivel assembly
- For use with oil, waste oil, diesel fuel, antifreeze, water & other fluids with a low flash point



BLACK KNIGHT LIQUID LEVEL GAUGE
#007600R

\$209

- 1 Gauge accommodates tanks up to 99"
- Measures inches on empty
- Large number display
- Direct drive
- 2" NPT Thread
- Oversized floats with swivel assembly
- For use with oil, waste oil, diesel fuel, antifreeze, water, & most liquids with a low flash point



25-GALLON UL DIESEL CADDY
#FC-25DC

\$729

- UL Listed and complies with OSHA guidelines
- 10" steel wheels
- Fill level gauge
- Fire-screened vent and filler neck
- 8' suction / discharge hose with internal steel grounding wire



25-GALLON UL LISTED GAS CADDY
#FC-25GC

\$759

- Designed for professional automotive service facilities
- Tested & approved to UL (MH62827) requirements for leakage, rupture, stability, abuse, & endurance
- For use with Gasoline, Diesel, Kerosene, Bio-Diesel, & Transmission Fluid
- 25-Gallon capacity steel tank
- UL Listed (MH62827) cast iron pump
- 10" steel wheels
- 8" PVC suction hose with internal steel grounding wire
- Fire-screened vent & filler neck



50:1 AIR OPERATED PORTABLE GREASE DISPENSING SYSTEM

- For use with 16-gallon containers
- Pumps up to 1.76 lb. per minute
- Includes grease control valve
- 13' delivery hose

#8600A

\$799

#8620A
Band dolly not included

\$899

#8621A
Band dolly included

\$899

#8622A
4-wheel heavy duty cart included

\$999

FUEL SERVICE TOOL
#38010000
(MODEL FST24)

\$299

- Cleans deposits from intake valves, fuel injectors & combustion chambers
- Restores lost power & improves fuel economy
- Lightweight fiberglass & aluminum construction
- Adjustable pressure regulator
- Works off shop air
- Adapters available



DIESEL INJECTION TOOL
#39010000
(MODEL DST32)

\$1,199

FINANCE:
\$31.80 / month for 60 months

- Reduces fuel system corrosion problems
- Removes deposits from injectors, improving injector spray pattern
- Removes combustion chamber & piston top deposits
- Reduces engine particulate emissions that clog EGR system coolers, valves & DPR system
- Improves fuel economy, engine power & responsiveness



BRAKE FLUSH ASSISTANT
#37010000
(MODEL BFA1)

\$1,999

FINANCE:
\$53.01 / month for 60 months

- Performs on low pressure & high pressure / hybrid systems
- Up to 120 PSI rating
- Light weight, easy to use
- Coalescing filter for air contaminant removal



POWER PROBE BRAKE MASTER CYLINDER ADAPTER KIT INCLUDED #BAKIT01 • VALUE: \$600

air compressors

3.5HP 230V 1PH 60-GAL SINGLE STAGE COMPRESSOR #6061V

\$1,329

FINANCE:
\$35.25 / month for 60 months

- 60 Gallon tank
- 12.4 ACFM @ 100 PSI
- 230 Volt single phase
- 135 Max pressure
- Cast iron cylinder



BelFire
COMPRESSORS

5HP 230V 1PH 60-GAL 2-STAGE COMPRESSOR #4916V

\$1,459

FINANCE:
\$38.69 / month for 60 months

- 15.3 ACFM @ 100 PSI
- No starter required
- 60 Gallon tank
- 165 Max pressure
- Ships "wet" ready to use
- 2 Year warranty



7.5HP 208-230 1PH 80-GAL 2-STAGE COMPRESSOR #318VL

\$2,849

FINANCE:
\$75.56 / month for 60 months

- 25.3 ACFM @ 100 PSI
- Starter included
- 208-230 1 Phase
- Ships "wet" ready to use
- 2 Year warranty



7.5HP 208-230 1PH 80-GAL 2-STAGE ELITE SERIES #318VLE

\$3,039

FINANCE:
\$80.59 / month for 60 months

- Includes low oil switch and auto drain
- 25.25 ACFM @ 100 PSI
- 175 PSI max pressure
- Ships "wet" ready to use
- 2-Year warranty



5HP 230V 1PH 60-GALLON 2-STAGE COMPRESSOR #2V41C60VC

\$1,699

FINANCE:
\$45.06 / month for 60 months

- 4 cylinder pump
- 15.4 ACFM @ 100 PSI
- No starter required
- 175 max PSI
- Made in USA



13HP HONDA 30-GALLON 2-STAGE SERVICE TRUCK COMPRESSOR #G213H30HCB

\$3,199

FINANCE:
\$84.84 / month for 60 months

- Electric and recoil start standard
- EZ pull tank drain
- 25.3 ACFM @ 100 PSI
- 175 PSI max pressure



5HP 230V 1PH 80-GALLON 2-STAGE MAX SERIES COMPRESSOR #251C80VCBM23

\$3,699

FINANCE:
\$98.10 / month for 60 months

- 17.7 ACFM @ 100 PSI
- Belt guard after-cooler
- Electronic tank drain
- Low oil level switch



7.5HP 230V 1PH 80-GAL 2-STAGE MAX SERIES COMPRESSOR #271C80VCBM23

\$3,999

FINANCE:
\$106.05 / month for 60 months

- 23.8 ACFM @ 100 PSI
- Belt guard after-cooler
- Electronic tank drain
- Low oil level switch



15HP 230V 3PH 120-GAL 2-STAGE MAX SERIES COMPRESSOR #2153DS12HCAM

\$6,799

FINANCE:
\$157.87 / month for 60 months

- 54.4 @ 100 PSI
- Belt guard after-cooler
- Electronic tank drain
- Low oil level switch



10HP YANMAR DIESEL 30-GAL 2-STAGE SERVICE TRUCK COMPRESSOR #D207Y30HC

\$6,999

FINANCE:
\$162.52 / month for 60 months

- 24.7 ACFM @ 100 PSI
- Pedestal style tank
- Electric and recoil start
- 175 max PSI
- Diesel powered



Quincy
COMPRESSOR

14 HP KOHLER 30-GALLON TANK COMPRESSOR + ALTERNATOR
#2475F14G

- 25.0 CFM
- Gas
- Includes start up kit



START UP KIT \$229
#4682-1567

- Engine: 2366-6845 & 2366-6852 filters, (2) quarts oil
- Pump: (2) 3217-0979 filters, (4) liters oil



\$3,379

FINANCE:
\$89.61 / month for
60 months

7.5HP (230V-1PH), PACKAGED, 80-GALLON V TANK COMPRESSOR
#2475N7.5-P-1

- 24.0 CFM
- Electric
- Includes start up kit



START UP KIT \$169
#3230-5880

- Pump: (2) 3217-0979 filters, (4) liters oil



\$3,609

FINANCE:
\$95.71 / month for
60 months

13 HP HONDA 30-GALLON TANK COMPRESSOR + ALTERNATOR
#2475F13GH

- 25.0 CFM
- Gas
- Includes start up kit



START UP KIT \$229
#3231-2936

- Engine: 2 quarts oil
- Pump: (2) 3217-0979 filters, (4) liters oil



\$3,879

FINANCE:
\$102.87 / month for
60 months

10HP (3PH), PACKAGED 120-GALLON H TANK COMPRESSOR
#2545E10-VP

- 35.0 CFM
- Electric
- No low oil switch



START UP KIT \$199
#3230-5898

- Pump: (2) 3201-2957 filters, (4) liters oil



\$4,209

FINANCE:
\$111.62 / month for
60 months

7.5HP (1PH) ROTARY COMPRESSOR
#UP6-7.5-1-120

- 25 CFM @ 150 PSI
- Enclosure (120g tank)
- UP6



\$6,439

FINANCE:
\$149.51 / month for
60 months

7.5HP (1PH) ROTARY COMPRESSOR
#UP6-TAS-7.5-1-120

- 25 CFM @ 150 PSI
- Dryer & Enclosure (120g tank)
- UP6



\$8,699

FINANCE:
\$201.99 / month for
60 months

ROTARY AIR COMPRESSOR BREAK IN KIT
#2335-2131

- 150 Hour
- One filter, one liter ultra coolant
- UP6: 5-15 HP

\$129



5HP 230V 1PH 60-GAL ROTARY SCREW COMPRESSOR
#QRS5.0HP-1

- 230 1 phase power
- Low sound-62 dBA
- 100% duty cycle
- 16.6 ACFM @ 150 PSI



\$5,399

FINANCE:
\$125.36 / month for
60 months

7.5HP 230V 1PH 60-GAL ROTARY SCREW COMPRESSOR
#QRS7.5HP-1

- 230 1 phase power
- Low sound-64 dBA
- 100% duty cycle
- 21.2 ACFM @ 150 PSI



\$5,599

FINANCE:
\$130.01 / month for
60 months

5HP 230V 1PH 60-GAL ROTARY SCREW COMPRESSOR + DRYER
#QRS5.0HPD-1

- 230 1 phase power
- Low sound-62 dBA
- 100% duty cycle
- 16.6 ACFM @ 150 PSI
- Refrigerated dryer included















\$6,999









FINANCE:
\$162.52 / month for
60 months



| | | | | | |
|---|---|--|--|--|---|
| 7.5HP 230V 1PH 60-GAL ROTARY SCREW COMPRESSOR + DRYER #QRS7.5HPD-1 | \$7,999 FINANCE: \$185.74 / month for 60 months | 10HP 208-230/460V 3 PH 132-GAL ROTARY SCREW COMPRESSOR + DRYER #QRS10HPD-150TM | \$8,799 FINANCE: \$204.31 / month for 60 months | 15HP 208-230/460V 3 PH 132-GAL ROTARY SCREW COMPRESSOR + DRYER #QRS15HPD-150TM | \$9,599 FINANCE: \$222.89 / month for 60 months |
| <ul style="list-style-type: none"> • 230 1 phase power • Low sound-64 dBA • 100% duty cycle • 16.6 ACFM @ 150 PSI • Refrigerated dryer included    |  | <ul style="list-style-type: none"> • 208-230/460 3 phase power • Low sound-65 dBA • 100% duty cycle • 35.2 ACFM @ 150 PSI • Refrigerated dryer included   |  | <ul style="list-style-type: none"> • 208-230/460 3 phase power • Low sound-69 dBA • 100% duty cycle • 51 ACFM @ 150 PSI • Refrigerated dryer included   |  |

| | | | | | | | |
|--|--|---|--|---|---|--|--|
| 5 HP 208-230V 1 PH 60-GAL 2-STAGE COMMERCIAL COMPRESSOR #CI51E63V | call for special pricing | 30-GALLON COMMERCIAL COMPRESSOR #CI8GEK33 | call for special pricing | 7.5 HP 208-230V 1 PH COMMERCIAL COMPRESSOR #R71ENC3 | call for special pricing | 25 HP 208-230V 3 PH COMMERCIAL COMPRESSOR #R253ENC6 | call for special pricing |
| <ul style="list-style-type: none"> • 200PSI ASME / CRN tank • 16CFM@175PSI   |  | <ul style="list-style-type: none"> • CH270 Kohler Electric start engine • 200PSI ASME/CRN tank • 18CFM@90PSI, 16CFM@175PSI   |  | <ul style="list-style-type: none"> • Rotary screw • Low sound enclosure • 30CFM@125PSI, 28CFM@150PSI   |  | <ul style="list-style-type: none"> • Rotary screw • 105CFM@125PSI, 100CFM@150PSI   |  |

INDUSTRIAL *Gold*

| REFRIGERATED DRYERS | | | | | |
|---|---|---|--|---|---|
| REFRIGERATED DRYER #D42IN | \$1,349 FINANCE: \$35.78 / month for 60 months | REFRIGERATED DRYER #D54IN | \$1,689 FINANCE: \$44.79 / month for 60 months | REFRIGERATED DRYER #D72IN | \$1,939 FINANCE: \$51.42 / month for 60 months |
| <ul style="list-style-type: none"> • 25 CFM @ 100° inlet • 100° ambient, 100 PSI • 110V - 1/2" NPT   |  | <ul style="list-style-type: none"> • 32 CFM @ 100° inlet • 100° ambient, 100 PSI • 110V - 1/2" NPT   |  | <ul style="list-style-type: none"> • 42 CFM @ 100° inlet • 100° ambient, 100 PSI • 110V - 1/2" NPT   |  |

IR Ingersoll Rand

25 CFM HIGH TEMP REFRIGERATED DRYER
#QRHT 25

- 115 volt power
- Free standing
- 180 degree inlet temperature
- Eliminates oil, water, and dirt from air
- 22.6x18.1x31.0 dimensions



\$2,299

FINANCE:
\$60.97 / month for
60 months



Freight Included

50 CFM HIGH TEMP REFRIGERATED DRYER
#QRHT 50

- 115 volt power
- Free standing
- 180 degree inlet temperature
- Eliminates oil, water, and dirt from air
- 20.4x13.8x17.7 dimensions



\$2,999

FINANCE:
\$79.53 / month for
60 months



Freight Included

AIR HOSE REELS



50' 3/8" ID HOSE REEL

- Value Series Air and Water 50' x 1/4" Retractable Hose Reel
- Spring-powered automatic recoil designed for indoor and outdoor use

#83753

\$189

50' 1/2" ID HOSE REEL

- Value Series Air and Water 50' x 1/2" Retractable Hose Reel
- 5-position adjustable outlet arm and no pump required

#83754

\$209



3/8" X 25' AIR HOSE REEL

- Heavy steel construction adds durability and longer life cycles
- Rubber air hose with heavy-duty crimping and spring guard
- Automatic return via heavy-duty sealed spring
- 300 PSI maximum pressure

#760

\$249

1/2" X 50' AIR HOSE REEL

- Heavy steel construction adds durability and longer life cycles
- Rubber air hose with heavy duty crimping and spring guard ensure longevity
- Mounting base is slotted and roller arm has five positions for multiple mounting configurations
- Automatic return via a heavy duty sealed spring with eight locking stops, roller guide and ball stop

#761

\$299



AIR, WATER & ATF HOSE REEL

1/2" X 50' • 3,000 PSI

#JD-1250

\$299

3/8" X 50' • 3,000 PSI

#JD-3850

\$329

GREASE HOSE REEL

1/4" X 50' • 5,000 PSI

#JDH-1450

\$379

OIL & ATF HOSE REEL

3/8" X 50' • 2,250 PSI

#JDM-3850

\$379

1/2" X 50' • 2,250 PSI

#JDM-1250

\$409



air tools



| | | | | | | | |
|--|--|--|---|--|--|---|---|
| 1/4" HEAVY-DUTY DIE GRINDER #M566DB | \$24⁹⁹ | UTILITY CUT-OFF TOOL #M563DB | \$29⁹⁹ | WHEEL LUG & LOCK REMOVAL KIT #LT-4300 | \$59⁹⁹ | TIRE BUFFER #327LS | \$129 |
| <ul style="list-style-type: none"> • For detail work & finishing • Variable speed throttle • 22,000 RPM • 90 PSI-6 CFM |  | <ul style="list-style-type: none"> • Great for cutting many types of sheet metal, fiberglass, bolts & muffler clamps • 20,000 RPM Free speed • 90 PSI-4 CFM |  | <ul style="list-style-type: none"> • 1/2" Twist Flip Style: 3/4" (19mm) & 13/16" (21mm) • Coarse & fine + 3 PC Extractor punch |  | <ul style="list-style-type: none"> • Quick Chuck (3,000 RPM) |  |
|  | | | | LOCK TECHNOLOGY | |  | |

SOCKETS

| | | | | | | | |
|--|---|---|--|--|---|--|---|
| 1/2" SOCKET #S412X13FTW | \$9⁹⁹ | 1/2" SOCKET #S412X13FD | \$9⁹⁹ | 1/2" SOCKET #S419X21MFD | \$9⁹⁹ | 1/2" SOCKET #S419X21MFETW | \$9⁹⁹ |
| <ul style="list-style-type: none"> • 3/4" x 13/16" X-Thinwall |  | <ul style="list-style-type: none"> • 3/4" x 13/16" Thinwall |  | <ul style="list-style-type: none"> • 19mm x 21mm Thinwall |  | <ul style="list-style-type: none"> • 19mm x 21mm X-Thinwall |  |
|  | | | | | | | |
| 1/2" SOCKET #S414X15FTW | \$11⁹⁹ | 1/2" SOCKET #LT-1240 | \$19⁹⁹ | 1/2" SOCKET #LT-1250 | \$19⁹⁹ | 1/2" SOCKET #LT-1260 | \$19⁹⁹ |
| <ul style="list-style-type: none"> • 7/8" x 15/16" Thinwall |  | <ul style="list-style-type: none"> • 21mm x 21.5mm • Chrysler & Dodge with 21mm chrome capped lugnuts |  | <ul style="list-style-type: none"> • 18.5mm x 19.5mm • GM with 19mm chrome capped lugnuts |  | <ul style="list-style-type: none"> • 22mm x 22.5mm • Dodge 16"-17" aluminum wheels with 22mm chrome capped lugnuts |  |
|  | | LOCK TECHNOLOGY |  | |  |  | |
| 1" DRIVE 5-PC SOCKET SET #SS8205WS | \$119 | 1" DRIVE 8-PC DEEP METRIC SOCKET SET #SS818D | \$199 | 1" DRIVE 10-PC SOCKET SET #SS8210HDW | \$219 | | |
| <ul style="list-style-type: none"> • SQ: 13/16" • DP: 27, 33, 35, 36, 41mm |  | <ul style="list-style-type: none"> • DP: 27, 30, 32, 33, 35, 36, 38, 41mm |  | <ul style="list-style-type: none"> • SQ: 13/16", 15/16" • CD: 1"x1-3/16"x1-1/2" CD • DP: 33mm, -1", 1-3/16", 1-3/4" TW, 1-1/16", 1-1/8", 1-1/4" |  | | |
|  | | | | | | | |

WRENCHES

| | | | | | | | |
|---|--------------------------|---|--------------|--|--------------|---|--------------|
| 1/2" DRIVE IMPACT WRENCH #M558DB | \$49⁹⁹ | 1/2" SUPER DUTY IMPACT WRENCH #M625 | \$129 | 1/2" DRIVE STUBBY AIR IMPACT WRENCH #M632 | \$129 | 1/2" X-TREME DUTY DRIVE IMPACT WRENCH #M631 | \$139 |
| <ul style="list-style-type: none"> • Built-in air regulator • 7,000 RPM • 90 PSI-4 CFM | | <ul style="list-style-type: none"> • Built-in air regulator with 6 torque settings • 7,000 RPM • 8 CFM | | <ul style="list-style-type: none"> • Ideal for tight spaces • 13,000 RPM • 90 PSI-7 CFM | | <ul style="list-style-type: none"> • Commercial duty twin hammer • Lightweight & compact • 9,500 RPM • 90 PSI-7 CFM | |
|  | |  | |  | |  | |

| | | | | | |
|--|--------------|---|--------------|--|--------------|
| 1/2" SQ DR IMPACT WRENCH #231HA-2 | \$169 | 3/4" DRIVE HEAVY-DUTY IMPACT WRENCH #M627 | \$219 | 3/8" SQ DR IMPACT WRENCH #2115TIMAX | \$299 |
| <ul style="list-style-type: none"> • 2" Extended Anvil • 470F-590R ft lbs. | | <ul style="list-style-type: none"> • 4,200 RPM • 700 ft./lbs. of torque • Built-in air regulator | | <ul style="list-style-type: none"> • Lightweight • 280 ft lbs. | |
|  | |  | |  | |

| | | | | | |
|--|--------------|--|--------------|---|--------------|
| 1/2" SQ DR IMPACT WRENCH #2235TIMAX | \$389 | 3/4" SQ DR IMPACT WRENCH #2145QIMAX | \$629 | 1" SQ DR IMPACT WRENCH #285B-6 | \$629 |
| <ul style="list-style-type: none"> • Lightweight • 900F-930R ft lbs. (Titanium Nose) | | <ul style="list-style-type: none"> • Light & quiet • 1,350 ft lbs. | | <ul style="list-style-type: none"> • 6" Anvil • 1,450 ft lbs. | |
|  | |  | |  | |

| | | | | | |
|---|--------------|---|--------------|---|--------------|
| CORDLESS 20V IQ KIT IMPACT WRENCHES #W7152-K12 | \$559 | CORDLESS 20V IQ KIT IMPACT WRENCHES #W7152-K22 | \$649 | CORDLESS 20V IQ KIT IMPACT WRENCHES #W7252-K22 | \$759 |
| <ul style="list-style-type: none"> • Includes: W7152, BL2022 battery, BC1121 charger, tool bag | | <ul style="list-style-type: none"> • Includes: W7152, (2) BL2022 batteries, BC1121 charger, tool bag | | <ul style="list-style-type: none"> • Includes: W7252, (2) BL2022 batteries, BC1121 charger, tool bag | |
|  | |  | |  | |



TOOL STORAGE



41" 19-DRAWER TECH SERIES COMBO

- 20-gauge steel with powder coat paint
- Box beam with gusseted corner construction
- 100 lb. rated soft close steel ball bearing drawer slides
- Barrel type key locks / one lock per box
- Drawer liners included
- Limited lifetime warranty

41" 11-DRAWER TECH SERIES ROLL CHEST

- 765 lb. HD casters 2 fixed 2 swivel / locking
- Pull handle mounts to either side

41" 8-DRAWER TECH SERIES TOP BOX

- 110V power strip + 2 USB connectors
- 2 gas charged lid shocks
- 2 flush mount lifting handles

| PRODUCT | PART # | PRICE | FINANCE |
|--|--------------|----------------|---------|
| 41" 19-DRAWER TECH SERIES COMBO - WHITE | #41TB-W | \$1,309 | \$34.71 |
| 41" 19-DRAWER TECH SERIES COMBO - BLACK | #41TB-BK | \$1,309 | \$34.71 |
| 41" 11-DRAWER TECH SERIES ROLL CHEST - WHITE | #BT411111-W | \$749 | N/A |
| 41" 11-DRAWER TECH SERIES ROLL CHEST - BLACK | #BT411111-BK | \$749 | N/A |
| 41" 8-DRAWER TECH SERIES TOP BOX - BLACK | #BC411081-BK | \$559 | N/A |
| 41" 8-DRAWER TECH SERIES TOP BOX - WHITE | #BC411081-W | \$559 | N/A |

26" 11 DRAWER PRO SERIES COMBO

- 18-gauge steel with powder coat paint
- Box beam with gusseted corner construction
- 100 lb. rated soft close steel ball bearing drawer slides with dual safety latches
- Barrel type key locks / one lock per box
- Limited lifetime warranty

26" 6 DRAWER PRO SERIES ROLL CHEST

- 2200 lb. HD casters 2 fixed 2 swivel / locking
- Pull handle mounts to either side

26" 5 DRAWER PRO SERIES TOP BOX

- 2 Gas charged lid shocks
- 2 Top box lifting handles



| PRODUCT | PART # | PRICE | FINANCE |
|--|------------------|----------------|---------|
| 26" 11-DRAWER PRO SERIES COMBO - WHITE | #26TB-R | \$1,539 | \$40.81 |
| 26" 11-DRAWER PRO SERIES COMBO - BLACK | #26TB-GY | \$1,539 | \$40.81 |
| 26" 6-DRAWER PRO SERIES ROLL CHEST - WHITE | #UAT2661L-W-1-R | \$939 | N/A |
| 26" 6-DRAWER PRO SERIES ROLL CHEST - BLACK | #UAT2661L-BK-1-R | \$939 | N/A |
| 26" 5-DRAWER PRO SERIES TOP BOX - WHITE | #UAC2651L-W-1-R | \$609 | N/A |
| 26" 5-DRAWER PRO SERIES TOP BOX - BLACK | #UAC2651L-BK-1-R | \$609 | N/A |



45" 19-DRAWER PRO SERIES COMBO

- 18-gauge steel with powder coat paint
- Box beam with gusseted corner construction
- 100 lb. rated soft close steel ball bearing drawer slides with dual safety latches (double on deep or load bearing drawers)
- Barrel type key locks / one lock per box
- Drawer liners included
- Limited lifetime warranty

45" 11-DRAWER PRO SERIES TOP BOX

- 2 Gas charged lid shocks
- 2 Top box lifting handles

45" 8-DRAWER PRO SERIES ROLL CHEST

- Full width bottom drawer
- 2200 lb. HD Casters 2 fixed 2 swivel / locking
- Pull handle mounts to either side

| PRODUCT | PART # | PRICE | FINANCE |
|--|--------------------|----------------|---------|
| 45" 12-DRAWER PRO SERIES WORKSTATION WITH STAINLES STEEL TOP - WHITE | #UAT451121L-BK-1-R | \$3,189 | \$84.57 |
| 45" 12-DRAWER PRO SERIES WORKSTATION WITH STAINLES STEEL TOP - BLACK | #UAT451121L-W-1-R | \$3,189 | \$84.57 |
| 45" 19-DRAWER PRO SERIES COMBO - WHITE | #45TB-R | \$2,699 | \$71.58 |
| 45" 19-DRAWER PRO SERIES COMBO - BLACK | #45TB-GY | \$2,699 | \$71.58 |
| 45" 11-DRAWER PRO SERIES ROLL CHEST - WHITE | #UAT450111L-W-1-R | \$1,649 | \$43.73 |
| 45" 11-DRAWER PRO SERIES ROLL CHEST - BLACK | #UAT450111L-BK-1-R | \$1,649 | \$43.73 |
| 45" 8-DRAWER PRO SERIES TOP BOX - WHITE | #UAC45081L-W-1-R | \$1,049 | \$27.82 |
| 45" 8-DRAWER PRO SERIES TOP BOX - BLACK | #UAC45081L-BK-1-R | \$1,049 | \$27.82 |
| 45" PRO SERIES STAINLESS STEEL WORKTOP | #P-WTS-UAT4501 | \$359 | N/A |

53" 20-DRAWER PRO SERIES COMBO

- 18-gauge steel with powder coat paint
- Box beam with gusseted corner construction
- 100 lb. rated soft close steel ball bearing drawer slides with dual safety latches (double on deep or load bearing drawers)
- Barrel type key locks / one lock per box
- Drawer liners included
- Limited lifetime warranty

53" 12-DRAWER PRO SERIES ROLL CHEST

- 2 Full width top drawers
- 2200 lb. HD casters 2 fixed 2 swivel / locking
- Pull handle mounts to either side

53" 8-DRAWER PRO SERIES TOP BOX

- 110V power strip + 2 USB connectors
- 2 Gas charged lid shocks
- 2 Flush mount lifting handles



| PRODUCT | PART # | PRICE | FINANCE |
|---|-------------------|----------------|---------|
| 53" 20-DRAWER PRO SERIES COMBO - WHITE | #53TB-W | \$3,299 | \$87.49 |
| 53" 20-DRAWER PRO SERIES COMBO - BLACK | #53TB-BK | \$3,299 | \$87.49 |
| 53" 12-DRAWER PRO SERIES ROLL CHEST - WHITE | #UAT530121-W-1-R | \$1,919 | \$50.89 |
| 53" 12-DRAWER PRO SERIES ROLL CHEST - BLACK | #UAT530121-BK-1-R | \$1,919 | \$50.89 |
| 53" 8-DRAWER PRO SERIES TOP BOX - WHITE | #UAC53081-W-1-R | \$1,379 | \$36.57 |
| 53" 8-DRAWER PRO SERIES TOP BOX - BLACK | #UAC53081-BK-1-R | \$1,379 | \$36.57 |





72" 19-DRAWER PRO SERIES COMBO

- 18-gauge steel with powder coat paint
- Box beam with gusseted corner construction
- 100 lb. rated soft close steel ball
- Barrel type key locks / one lock per box
- Stainless steel top & drawer liners included
- Limited lifetime warranty

72" 19-DRAWER PRO SERIES ROLL CHEST

- 2200 lb. HD casters 2 fixed 2 swivel / locking
- 110V Power Strip with USB outlets
- Pull handle mounts to either side

72" HUTCH

- Two Gas Charged Cover Shocks & Movable Shelf
- Square Hole Back Panel
- 110V Power Strip with USB Outlets



*Freight not included

| PRODUCT | PART # | PRICE | FINANCE |
|--|-------------------|----------------|----------|
| 72" 19- DRAWER PRO SERIES COMBO - WHITE | #72HB-W | \$6,049 | \$140.46 |
| 72" 19- DRAWER PRO SERIES COMBO - BLACK | #72HB-BK | \$6,049 | \$140.46 |
| 72" 19- DRAWER PRO SERIES ROLL CHEST - WHITE | #UAT720191-W-1-R | \$4,399 | \$116.66 |
| 72" 19- DRAWER PRO SERIES ROLL CHEST - BLACK | #UAT720191-BK-1-R | \$4,399 | \$116.66 |
| 72" HUTCH - WHITE | #UAC720001S-W* | \$1,649 | \$43.73 |
| 72" HUTCH - BLACK | #UAC720001S-BK* | \$1,649 | \$43.73 |

54" 19-DRAWER ELITE SERIES COMBO

- 15-gauge steel with powder coat paint
- 220 lb. rated soft close steel ball bearing drawer slides
- Limited lifetime warranty

54" 11-DRAWER ELITE SERIES ROLL CHEST

- 3300 lb. HD casters 4 fixed 4 swivel / locking
- Pull handle mounts to either side

54" 8-DRAWER ELITE SERIES TOP BOX

- 2 Gas charged lid shocks & 2 Top box lifting handles



*Freight not included



| PRODUCT | PART # | PRICE | FINANCE |
|--|---------------|----------------|----------|
| 54" 19-DRAWER ELITE SERIES COMBO - RED | #54TB-R | \$9,489 | \$220.33 |
| 54" 19-DRAWER ELITE SERIES COMBO - BLACK | #54TB-BK | \$9,489 | \$220.33 |
| 54" 11-DRAWER ELITE SERIES BOTTOM ROLL CHEST WITH SS TOP - RED | #54SSTB-R | \$6,519 | \$151.37 |
| 54" 11-DRAWER ELITE SERIES BOTTOM ROLL CHEST WITH SS TOP - BLACK | #54SSTB-B | \$6,519 | \$151.37 |
| 54" 11-DRAWER ELITE SERIES ROLL CHEST - RED | #ATA540111-R | \$5,829 | \$135.35 |
| 54" 11-DRAWER ELITE SERIES ROLL CHEST - BLACK | #ATA540111-BK | \$5,829 | \$135.35 |
| 54" 8-DRAWER ELITE SERIES TOP BOX - RED | #ACA540081-R | \$3,659 | \$97.04 |
| 54" 8-DRAWER ELITE SERIES TOP BOX - BLACK | #ACA540081-BK | \$3,659 | \$97.04 |
| 54" ELITE SERIES STAINLESS STEEL WORKTOP | #P-WTS-ATA54* | \$689 | N/A |



33-1/2" PRO SERIES SIDE LOCKER

- Reversible door with full length hinge; Single barrel key lock with two lock rods
- Two adjustable shelves + rubber top pad
- Limited lifetime warranty
- 15 5/16" W X 17 15/16" D X 33 1/2" H

BLACK
#AT1800-BK **\$279**

WHITE
#AT1800-W **\$279**



2-DRAWER TECH SERIES FLIP-TOP SERVICE CART

- 20-gauge steel
- 2 removable drawers, 4 5" HD Swivel Casters
- Pull handle can be mounted on either side
- Flip top features two gas shocks to hold lid open
- Limited lifetime warranty
- 30" W X 20" D X 36" H

#UAS3321-GY **\$549**



2-DRAWER TECH SERIES MOBILE COMPUTER SERVICE CART + LOCKING CABINET

- 20-Gauge steel with powder coat
- 2 Removable drawers, (4) 5" HD swivel casters, two locking
- Mounting tabs to secure computer & Peg board sides
- Bulk storage area with & single key lock security
- Limited lifetime warranty
- 44" W X 22" D X 20" H

#ECC22041DG **\$549**



35" PRO SERIES SERVICE CARTS

- 18-Gauge steel with powder coat paint
- 110v power strip with USB ports located in top tray
- Removable drawers , (2) long bar storage areas located in top trays
- Single drawer lock lever in open top area / single barrel key lid lock
- Flip top features two gas shocks to hold lid open; Pull handle can be mounted on either side
- (4) 5" HD swivel casters, (2) locking
- Limited lifetime warranty
- 30" W X 20" D X 36" H

BLACK
5-DRAWER
#UAS341051-BK **\$999**

WHITE
5-DRAWER
#UAS341051-W **\$999**



3-DRAWER WITH SLIDE TOP

BLACK
#UAS340071-BK **\$1,099**

WHITE
#UAS340071-W **\$1,099**

FINANCE:
\$29.15/month for 60 months

FINANCE:
\$29.15/month for 60 months



BUY (1) QUALIFYING SHOCKWAVE IMPACT™ SOCKET SET

GET (1) DRIVER SOCKET SET FREE

REDEEMED VIA E-REBATE #49-66-7025 ONLY



49-66-7011
12pc Shockwave Impact Duty™ 1/2" Drive SAE Deep 6 Point Socket Set
\$79.99



49-66-7014
14pc Shockwave Impact Duty™ 1/2" Drive Metric Deep 6 Point Socket Set
\$85.99



49-66-7025
3pc Shockwave Impact Duty™ 1/2" Drive Metric Deep 6 Point Socket Set
\$18 VALUE



49-66-7006
12pc Shockwave Impact Duty™ 3/8" Drive SAE Deep 6 Point Socket Set
\$64.99



49-66-7008
14pc Shockwave Impact Duty™ 3/8" Drive Metric Deep 6 Point Socket Set
\$59.99

BUY (1) QUALIFYING SHOCKWAVE IMPACT™ SOCKET SET

GET (1) RIGHT ANGLE ADAPTER FREE

REDEEMED VIA E-REBATE #48-32-2390 ONLY



48-32-4028
Shockwave™ Impact Duty Drill & Drive Set - 55pc
\$44.99



48-32-2390
Shockwave™ Right Angle Adapter
\$25 VALUE



BUY (1) 29 PC COBALT TWIST DRILL BIT SET

GET (1) SNAPBACK TRUCKER HAT FREE

REDEEMED VIA E-REBATE #505B ONLY



48-89-2332
29pc Red Helix™ Cobalt Drill Bit Set
\$139



505B
Gridiron™ Snapback Trucker Hat
\$25 VALUE



Milwaukee products must be purchased in the promotional period of 1/1/22 – 3/31/22 from a participating Milwaukee Tool dealer. All redemption offers must be received with required information by close of business 4/15/2022. Only one redemption per transaction. Limit 5 rebates per customer. Cannot be used in conjunction with any other offer.



Nothing but **HEAVY DUTY**®

BUY (1) M12 FUEL KIT BARE TOOL

BUY (1) M12 FUEL KIT



0960-20
1.6 Gallon
Wet/Dry
Vacuum
\$129

2522-20
3" Compact
Cut Off Tool
\$139



2567-20
3/8" High
Speed Ratchet
\$179



2520-21XC
Hackzall Kit
W/1 XC Bat.
\$179



2438-22X
Variable Speed
Polisher/Sander Kit
\$249



2554-20
Stubby
3/8" Impact
Wrench
\$179



2526-20
Oscillating
Multi-Tool
\$149



2596-22
1/2" Drill Driver & Impact
Kit
\$229



2505-22
Installation Drill/Driver Kit
\$229

GET YOUR CHOICE (1) FREE
REDEEMED VIA E-REBATE

GET YOUR CHOICE (1) FREE
REDEEMED VIA E-REBATE



49-90-1900
Wer/Dry
Filter Kit
\$20 VALUE

49-94-3000
3" Cut Off
Blade 3pk
\$15 VALUE



SCAN ME



49-16-2554
M12 Fuel™ Stubby
Protective Boot
(2554/2555/2555P)
\$30 VALUE



49-16-2567
1/4" & 3/8"
High Speed Ratchet
Protective Boot
\$30 VALUE



49-25-1251
Milwaukee®
Open-Lok™ 1-1/8"
Titanium Enhanced
Bi-Metal Blade 1pk
\$15 VALUE



2460-20
M12™ Rotary Tool
\$79 VALUE



2426-20
M12™ MULTI-TOOL
\$79 VALUE



SCAN ME



2457-20
M12™
3/8" Ratchet
\$129 VALUE



2415-20
M12™ 3/8"
Rad Drill
\$79 VALUE

Milwaukee products must be purchased in the promotional period of 1/1/22 – 3/31/22 from a participating Milwaukee Tool dealer. All redemption offers must be received with required information by close of business 4/15/2022. Only one redemption per transaction. Limit 5 rebates per customer. Cannot be used in conjunction with any other offer.

BUY
(1) M18 FUEL
BARE TOOL



0970-20
PACKOUT™
2.5 Gallon
Wet/Dry
Vacuum
\$199



2880-20
4-1/2\"/>



2719-20
Hackzall™
\$159



2821-20
Sawzall® Recip Saw
\$199



2854-20
3/8\"/>

GET
YOUR
CHOICE (1)
FREE

REDEEMED VIA E-REBATE



SCAN ME



49-90-1900
Wer/Dry Filter Kit
\$20 VALUE



49-16-2854
M18 Fuel Compact
Impact Wrench
Protective Boot
\$30 VALUE

48-00-5784
6\"/>

\$15 VALUE



49-93-7805
4-1/2\"/>

BUY
(1) M18 FUEL DRILL KIT

GET THIS
FREE

REDEEMED VIA E-REBATE



SCAN ME



2803-22
Drill Driver Kit
\$289

48-89-0011
THUNDER-
BOLT® Titanium
Coated Drill Bit
Set -14 pc
\$30 VALUE



Milwaukee products must be purchased in the promotional period of 1/1/22 – 3/31/22 from a participating Milwaukee Tool dealer. All redemption offers must be received with required information by close of business 4/15/2022. Only one redemption per transaction. Limit 5 rebates per customer. Cannot be used in conjunction with any other offer.

BUY (1) M12 FUEL BARE TOOL



2111-21
USB Rechargeable
Hard Hat Headlamp
\$69.97



2115-21
USB Rechargeable
Low-Profile Headlamp
\$69.97



2112-21
USB Rechargeable Rover™
Pocket Flood Light
\$59.97



2160-21
USB Rechargeable
800L Compact
Flashlight
\$69.99



2161-21
USB Rechargeable
1100L Twist Focus
Flashlight
\$79.99

**GET
YOUR CHOICE (1)
FREE**
REDEEMED VIA E-REBATE



SCAN ME



503B
Cuffed Beanie
Black
\$20 VALUE



503R
Cuffed Beanie
Red
\$20 VALUE



503HV
Cuffed Beanie
High Vis
\$20 VALUE

BUY (1) 32 PC SAWZALL® BLADE SET



49-22-1132
SAWZALL BL
MEGA SET -
THIN KERF &
DEMO 32PC
\$89.97

**GET
YOUR CHOICE (1)
FREE**
REDEEMED VIA E-REBATE



SCAN ME



48-00-5326
The Ax™ with
Carbide Teeth 5T
9L 3pk
\$39 VALUE



48-00-5342
9\"/>



48-00-5302
The Torch™ with
Carbide Teeth 7T
9L 3pk
\$39 VALUE

Milwaukee products must be purchased in the promotional period of 1/1/22 – 3/31/22 from a participating Milwaukee Tool dealer. All redemption offers must be received with required information by close of business 4/15/2022. Only one redemption per transaction. Limit 5 rebates per customer. Cannot be used in conjunction with any other offer.

drill bits

2-PACK METAL SERIES RECIP BLADES

\$6⁹⁹

- Unique nitro hardening process for optimal strength and blade life
- Cobalt matrix teeth are fused to a flexible, shatterproof shock absorbing alloy backbone for rugged cutting
- 1-inch width and heavy-duty blade thickness for clean cuts with less vibration in heavy metal cutting applications
- 1/2-inch universal shank with 5% tilt angle for faster cuts and skid-free starts

#7489
• 8/10T X 6"



#7890
• 8/10T X 9"



#7498
• 14/18T X 6"



#7898
• 14/18T X 9"



5-PACK 18T & 24T PORTA BAND SAW BLADES #15718 & #15724

\$29⁹⁹

- Cobalt Bi-Metal teeth with 8% cobalt for a longer cutting life
- For cutting aluminum, iron, bronze, brass, copper, galvanized pipe, stainless and tungsten steel
- Fits all brand band saws that require 44-7/8" blades
- Made in USA



29-PC PRO-GRADE BLACK OXIDE DRILL BIT POD -3/8" RS #24538

\$79⁹⁹

- Set includes: 1/16" - 1/2" drills
- Manufactured from industrial high-speed steel, surface treated for high performance and long life
- M2 grade steel for drilling common steel (flat bar, angle iron, tubing), wood and plastic
- 135-degree quick-cut point
- Manufactured to Aerospace NAS 907-B specifications



29-PC PRO-GRADE COBALT DRILL BIT POD #26529

\$129

- Set includes: 1/16" - 1/2" drills
- Made from M42 steel with 8% cobalt Century's Cobalt drill bits are designed to cut through extremely hard metals, including stainless steel
- 135-degree quick-cut point
- Extremely heat resistant, must be used and operated in power units that have an RPM speed of 1,500 or more for maximum efficiency



5-PC LONG PIN PUNCH SET #W758

\$13⁹⁹

- Carbon steel pin sizes: 1/8", 3/16", 1/4", 5/16" & 3/8"



9-PC LONG PIN PUNCH SET #W7559

\$16⁹⁹

- Pin sizes: 1/16", 5/64", 3/32", 1/8", 5/32, 3/16", 7/32, 5/16"



5-PC LONG PIN PUNCH SET #W759

\$25⁹⁹

- Brass pin sizes: 1/8", 3/16", 1/4", 5/16" & 3/8"



40-PC TAP & DIE SET #W4001DB (SAE) | #W4002DB (METRIC)

\$28⁹⁹

- NC, NF & NPT sizes
- Blow molded plastic storage case
- Set includes: 17 taps & 17 dies, tap wrench, T-handle tap wrench, die stock, screwdriver & screw pitch gauge



28-PC PUNCH & CHISEL SET #W754

\$44⁹⁹

- Set includes: 16 PC chrome vanadium punch & chisel set, 5 PC pin punches, 5 PC taper punch, 3 PC cold chisel, 2 PC center punch & chisel punch gauge, 12 PC high carbon steel set, 6 PC cold chisel set, 4 PC punch set & 2 PC center punch
- Complete with roll-up vinyl storage pouch



NEW YEAR. NEW GOALS.

START 2022 WITH AN INVESTMENT IN **YOURSELF** *and your company.*



BECOME A MEMBER OF **THE GROUP TRAINING ACADEMY!**



JANUARY 2022
HIGH VOLTAGE COMPONENT STRATEGIES



FEBRUARY 2022
ADAS OPERATIONS



MARCH 2022
LEAK DETECTION, A/C DIAGNOSTICS



For more information visit:
www.TheGroupTrainingAcademy.com

specialty tools

DEF FUNNEL KIT #7220

\$40⁹⁹

- Allows fast and clean filling of DEF (Diesel Exhaust Fluid), also known as Ad Blue
- Special threaded connector to fit all standard DEF systems
- Elbow adapter to create angle
- Shut-off valve to prevent spillage
- Air-bleed line for fast flow
- Built in screen to prevent contaminants entering system
- Funnel body features wide-mouthed opening & built in handle
- Allows easy, one-man, filling with large (10L) containers, saving time & money



E-Z CHAMFER TOOL #3838

\$48⁹⁹

- 5 Point design for quick and clean deburring
- Single M2-HSS Construction - tungsten-moly high speed steel with well balanced composition for a wide variety of applications and materials
- Efficiently removes burrs and ridges from bolts, pipe, threaded rod, bar and dowels
- Suitable for use on metals ranging from Mild to Super Hard Steel US Grade ASTM-A574 Metric Grade 12.9



DIGITAL CIRCUIT TESTER KIT #5059

\$64⁹⁹

- Used to check voltage value on 6, 12 & 48V systems
- Full voltage measurement range: 4V - 60V
- Small testing current < 10mA
- Coil cord stretches 12'
- Digital display reads accurate voltage value
- LCD screen displays power (Red) and ground (Green)
- Utilizes standard 4mm banana jacks to ensure compatibility with most circuit testing equipment and meters
- Kit includes: Piercing probe w/ banana socket, Insulated cable piercing probe with banana socket, Test probe with 4mm banana socket, and alligator clip



7-PC DEUTSCH TERMINAL TOOL KIT #2246

\$64⁹⁹

- High quality steel tip terminal tools prevent damage to wires and terminal blocks
- Includes 7 Deutsch Terminal Tools from #9812 Kit packed in pouch for easy access and organized storage



UNIVERSAL LOCKING RING TOOL #4031

\$119

- Safe and strongest tool for lock ring service
- Hold handle while adjusting screw mechanism to control forged jaws to remove and install lock rings securely and quickly
- Services CV shaft, wheel hub, axle shaft, cam shaft, etc.
- Includes 3 pairs of tips: 2.5mm, 3mm & 3.5mm



MASTER KIT #4031M

\$169

- Includes 12 pairs of tips in straight, 45° & 90° variants, sizes: 2.5mm, 3mm, 3.5mm, & 3.8mm



26-PC TERMINAL TOOL KIT #9812

\$139

- High quality steel tip terminal tools
- Includes newest designed tips for service on most vehicles on road
- For both import and domestic vehicles, plus special tools for coolant sensors, wiring harnesses and terminal blocks on most modern vehicles
- Includes application chart with a cross reference for terminal brands



RADIATOR PRESSURE TESTER KIT #7050

\$179

- Tests automotive pressurized cooling systems up to 30 PSI
- Kit includes pump with gauge, 12" hose and cap adapter to check 3/4" deep filler necks, 1/4" Spacer Washer for testing 1" deep filler necks, plus 3 Radiator Adapters (#7090, #7091 & #7092)
- Services most Domestic and Asian Vehicles



MASTER CYLINDER BRAKE BLEEDER ADAPTER KIT #7300

\$259

- 10 Master Cylinder Adapters, plus 1 Quick Coupler, working with #7015 Pressure Bleeder Tank will service most makes & models
- Packaged in blow mold case for safe easy access and optimal organization
- Includes ID chart for quick retrieval of correct adapter





DEEP METRIC SOCKETS

- 120mm long sockets for extra-deep reach
- Provides access to recessed areas with extra long bolts, as found on some bumpers, rear lamps, glow plugs and door hinge fittings
- 3/8" square drive - #1099 includes 1/4" to 3/8" square drive adapter

#1710
(10 MM)

\$12⁹⁹

#1711
(11 MM)

\$12⁹⁹

#1030
(2-PC SET:10 &12 MM)

\$24⁹⁹

#1700
(5-PC SET)

\$56⁹⁹

#1099
(COMPLETE 11-PC SET: 8-18 MM)

\$139



7-PC EXTRA LOW PROFILE OIL FILTER SOCKET SET

- Full range of extra-low profile oil filter housing cap sockets, sizes: 24mm, 25mm, 27mm, 28mm, 29mm, 32mm, 36mm
- Services vehicles with oil filter housing caps
- All sockets 3/8" square drive & extra low profile sockets for tight clearances
- Packed in blow mold case

#7995

\$39⁹⁹



6-PC MINI METRIC FLIP SOCKET SET

- 12-Pt semi deep mini flip sockets with 1/4" drive
- Services brake bleeder nuts, battery terminals, under belly pans/trays, intake fasteners, body panels, & more
- Socket sizes: 8mm/10mm, 9mm/11mm, 12mm/14mm, & 13mm/15mm
- Includes (2) 1/4" hex to square extensions size 3" and 5"

#4223

\$48⁹⁹



FORD TRANSIT HUB NUT SOCKET

- HD 4-Pt specialized impact socket for removing the rear hub nut on RWD Ford Transit
- Alignment shaft allows accurate placement onto the castle nut
- Services 2014 & up Ford Transit vehicles
- Comparable to Ford Factory Tool # 205-1007

#1083

\$64⁹⁹



4-PC SPARK PLUG SWIVEL SOCKET SET EURO

- 14mm & 16mm 12 point 15-20°
- Services many BMW, Benz, MINI, Infinitie & Porsche
- Includes: #1061 - 14mm (OAL: 3.5"), #4329 - 16mm (OAL: 3.5"), #7654 - 14mm (OAL: 8.5"), & #7656 - 16mm (OAL: 8.5")

#2030

\$79⁹⁹



5-PC SPARK PLUG SOCKET SET

- Comprehensive kit services wide range of vehicles
- Includes extra-long 10" sockets
- All sockets magnetic except 2376 - 14mm x 12 Pt.
- Includes sizes: #1730 - 5/8" x 12 Pt (OAL: 6"), #2380 - 5/8" x 6 Pt (OAL: 10"), #2390 - 9/16" x 6 Pt (OAL: 10"), #2394 - 14mm x 6 Pt (OAL: 10"), & #2376 - 14mm x 12 Pt (OAL: 2.5")
- All sockets also available as open stock

#5061

\$96⁹⁹



8-PC VIBROSHOCK SOCKET KIT

- Removes frozen or rusted screws, nuts, bolts or plugs
- Articulated wrench is integrated on the axle
- Set includes: Vibro-shaft with articulated wrench & 7 Metric Impact Sockets sizes: 8, 9, 10, 11, 12, 13, 14mm - all 3/8" square drive & special "Internal Edge"
- Bolts rest on internal edge of socket, directing vibration on head of the bolt, preventing damage and breakage

#1000

\$96⁹⁹



8-PC OIL DRAIN PLUG KIT

- Removes plastic oil & radiator drain plugs without damage
- Contains a T-handle with a square drive ball lock and 7 adapters

#1320

\$72⁹⁹



UNIVERSAL HUB & DRUM PULLER

- Frees frozen hubs, axle shafts, & other tough pulling applications
- Adjustable sliding legs can be positioned anywhere on the center hub ring
- Maximum bolt pattern 7-1/2" (190.2mm), also removes press-fit rear brake drums
- Makes wheel hub removal quick, easy & damage free

#W89325

\$109



**GLOW PLUG TIP
PULLER KIT
#7802**

\$319

- Removes broken glow plug tips stuck in the cylinder head
- The tap, drill bit and extractor holders are fitted to the body of the original plug
- Self-centering industrial taps with "stop-block"
- Kit services limited clearances
- Works on majority of Import/Euro diesel passenger vehicles



**GLOW PLUG
PULLER KIT
#7804**

\$429

- Includes: (1) electrode puller, (1) electrode reinforced drill with (2) guides, (2) specially centered mills with one mill support, (1) tap and (1) slide hammer extractor, (3) refreshing taps sizes: M8, M10x100 & M10x125 with hex drive



**HUB & BEARING
SERVICE KIT
#6575**

\$699

- FWD Bearing Adapter Kit & Puller (Hub Grappler)
- Complete solution for servicing wheel hubs and bearings without removing the steering components or knuckle
- Eliminates unnecessary alignments or the use of a shop press



WRENCHES



- 8-iN-1 Multi-Wrench 12-19mm Hex - Box
- Sizes: 12, 13, 14, 15, 16, 17, 18, 19mm

#2495K

\$41⁹⁹



- 8-in-1 Oil & Lube Multi-Wrench Male Square & Hex
- Square sizes: 8mm, 10mm, 3/8", 1/2"
 - Hex: 10, 12, 14, 17mm

#2497K

\$41⁹⁹



- Chain Wrenches
- Extra Long HD Chain wrenches are designed to handle standard and irregular shapes
 - Double action head
 - Ratcheting action
 - Comfort grip handle

#5052 (36" HD)

\$109

#5053 (48" HD)

\$119

TOYOTA OIL FILTER WRENCHES



- 4-Cylinder OFW
- Slim design allows clearance of oil pan to properly access and engage housing cap on 4-cylinder models

#2477

\$26⁹⁹



- 4-1, 6 & 8-Cylinder Aluminum die-cast OFW
- Aluminum die-cast with notches

#2465

\$26⁹⁹



- 4, 6 & 8-Cylinder OFW
- Steel construction with 1/2" Square Drive and deep reach for clearance

#1726

\$36⁹⁹





- Extra HD, 6 & 8-Cylinder steel forged OFW Forged and machined from 6140 steel with notches

#2475

\$36⁹⁹

- OFW set with hoses
- 3 PC set includes: #2475, #2477 & #2088 (Toyota Drain Hose)

#2470

\$68⁹⁹**SPECIALTY TOOLS****PUSH PIN PLIERS**

- Specially designed to remove push pins with center locking pin
- Quickly & easily removes plastic anchors without damage
- Fits common anchors on Honda, Toyota, GM, Ford, Chrysler & many other makes

#W86561

11⁹⁹**MINI BULB PLIERS**

- Gently and firmly grips glass shell of bulb
- For all types of bulbs
- Cup-type ends create circular gripping area
- Rubber coated gripping area

#1012

\$12⁹⁹**FUEL LINE CLIP REMOVAL PLIERS**

- For releasing connections on fuel lines during maintenance or replacing fuel filters
- Designed to compress the quick disconnect lugs
- Works on VW & Audi fuel lines with plastic snap-together connectors
- Mercedes M-Class fuel filters, Ford, Mazda, Fiat, GM & BMW's

#W83115

\$12⁹⁹**8-PC SCREW EXTRACTOR SET**

- Use with T-handle or wrench to remove broken & stripped screws
- Drop forged, heat treated carbon steel for long life
- Tapered counter clockwise threads
- Comes with blow mold storage case
- Spiral extractor sizes #1-#8

#W2968

\$12⁹⁹**QUICK CHANGE TUBING BENDER**

- Capacity 3/16", 1/4", 5/16" & 3/8" outside diameter
- Bends brass, copper, aluminum & steel tubing
- Designed to allow bending in tight spaces
- Cushion grip handles reduce hand fatigue & slippage
- Anvil easily slides for quick adjustments to multiple tubing sizes

#W80673

\$26⁹⁹**3-IN-1 MULTI-CUTTER**

- 3 tools in one: anvil cutter, wire cutter & box cutters
- Razor sharp blades
- Titanium coated wire cutter
- Retractable anvil
- Comfortable slip resistant grip

#W2045

\$28⁹⁹**UNIVERSAL HOSE CLAMP PLIERS**

- Frees frozen hubs, axle shafts, & other tough pulling applications
- Adjustable sliding legs
- Maximum bolt pattern 7-1/2" (190.2mm)
- Wheel hub removal quick, easy & damage free

#W80659

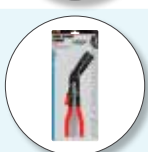
\$29⁹⁹**UNIVERSAL HOSE CLAMP PLIER ANGLE**

- Special angle jaw design, quick position locking mechanism
- Access a variety of hard to reach clamps, tank ventilation lines, radiator clamps
- Steel construction with cushion grips
- 1-1/4" x 3/4" head with multi-directional slotted pattern

#W80667

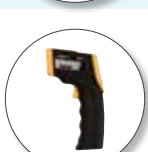
\$29⁹⁹**INFRARED THERMOMETER**

- -58~716 °F (-50~380 C)
- Accuracy +/-2%
- Distance spot ratio 8:1
- Laser pointer for accurate use
- Home, auto & industrial use

#W89721

\$33⁹⁹

**1200+ LUMEN LED
DROP LIGHT**
#W2240

\$34⁹⁹

- Built-in lithium ion batteries
- Produces over 1200 lumens of bright white light
- 2 hour runtime, 4 hour charging time



**151 PC. RATCHETING
CRIMPER SET**
#W185

\$41⁹⁹

- Crimps wires & cables with a professional & secure connection
- Designed for 10 to 22 gauge wire
- Includes 150 piece assortment of 10 to 22 gauge connectors



**GM TORSION BAR
UNLOADING TOOL**
#W83026

\$51⁹⁹

- Designed to hold the torsion bar while making adjustments, or replacing keys
- Heavy-duty forged steel with a larger 7/8" diameter threaded screw
- Designed to handle GM's K-3500 series trucks with heavy-duty chassis & a larger torsion bar
- Features a larger C-frame opening to accommodate beefier torsion bars



**FORD TIMING
TOOL SET - 1.6L**
#5068

\$47⁹⁹

- Ford 1.6L NA & 1.5L/1.6L EcoBoost Sub Kit includes: 2880X03 - T.D.C. Crank Timing Pin, 1090 - VCT Alignment Tool, 1806 - Crankshaft Vibration Dampener Alignment Tool, & 5068X01 - L-Pin



**FORD 2.0L ECOBOOST
TIMING TOOL KIT**
#5067

\$57⁹⁹

- Ford 2.0 & 2.3L EcoBoost Timing Tool Sub Kit
- Includes: 2880X04 - T.D.C. Crank Timing Pin, 1026L - Camshaft Alignment Tool, & 1804 - Crankshaft Positioning Tool



**MASTER FORD
TIMING KIT**
#2221

\$179

- Services Ford, Mazda & Lincoln 1.4L, 1.5L, 1.6L, 2.0L, 2.3L, 2.5L, & 3.0L engines (variations of the EcoBoost, Duratec Flex Fuel & GTDI engine models from mid-90's through today)
- Includes: 1025 - Harmonic Balancer Holder, 1025 - Harmonic Balancer Holder - 2.5L, 3.0L & 3.5L, 1026L - Camshaft Alignment Tool, 1090 - VCT Alignment Tool - 1.6L, 1804 - Crankshaft Positioning Tool, 1806 - Crankshaft Vibration Dampener Alignment Tool, 2223 - 3 Pc. Wedges - 1.4L & 1.6L, 2880 - Camshaft Timing Kit, & 2884 - Cam Alignment Tool



ATF FILLING SYSTEM
#7400

\$179

- 9 liter (10 quart) tank unit dispenses fluid under pressure
- Built-in manual pump, with locking feature
- Removable 1.5 meter (5') clear dispensing hose + features spring protection
- Levered ball valve controls flow and includes hang hook
- Other tank features include 0 - 35 PSI (0 - 2.5 bar) gauge, fill hole, double-handle for carrying, air-valve release and rubberized belt to hold adapters
- Complete range of adapters are available as set or individually



15-PC ATF FILLING ADAPTER KIT
#7402

\$179

- Comprehensive set of ATF adapters to service most makes and models
- Compatible with CTA #7400 ATF Filling System Tank
- Packed in blow mold case for organization and storage



UNIVERSAL LINE KIT
#7662

\$209

- Comprehensive electrical testing kit
- Effortlessly analyze voltage, continuity, impedance and current
- Safety covers for sharp stainless steel probe tips
- Constructed of PP (polypropylene) - a stronger and more durable material
- 1000V & 30 Amps plus CE certificated
- Includes 5KΩ variable resistor potentiometers (2), alligator clips (2), articular probes (4), LED stroboscope (2), SRS Connector (2), 1 to 2 connector (2), 1 to 1 extension cable (4), probe (2), round male terminals w/ female banana socket (12), flat male terminals w/ female banana socket (24), flat female terminals w/ female banana socket (24) & round female terminals w/ female banana socket (12)



LUG DRILLER LUG NUT REMOVER KIT
#1775

\$349

- Removes the most difficult locking lug bolts quickly, safely and without damage
- Great for all vehicles with lost or damaged locking lug bolt keys
- Approximately 8-13 minute operation time per wheel
- Includes: (4) internal centering guides, (4) external centering guides, (2) tungsten carbide tip drills, (4) extractors, (1) impact extractor holder, & (1) impact extractor remover



lighting

MULTI-FUNCTIONAL FASTENERS #ACS201P

\$19⁹⁹

- Detachable multi-functional fasteners pair with tripod stand and wheel stand for hanging Underhood Light Series



150LM RECHARGEABLE LED & LASER PEN LIGHT #PEN151R

\$39⁹⁹

- Top: 100lm 4/2/2.5h operating time (step 1/2 top) 3.7V 750mAh Li-on battery
- Ultra-light weight, small & sturdy
- Front COB LED provides 150/75lm brightness
- Metal clip at back for easy to carry
- No Adapter



SLIM LIGHT 150 LM #SLM151R

\$42⁹⁹

- Front: 75/150lm Top: 100 lm 4/2/2.5h operating time (step 1/2 top)
- Ultra-light weight, small & sturdy
- Front COB LED provides lights with up to 150lm
- 100lm top high-power LED lamp
- Strong built-in magnets
- Fluorescent reflector



SLIM LIGHT 400 LM #SLM401R

\$54⁹⁹

- Front: 200/400lm
- Top: 100lm 4/2/2.5h operating time (step 1/2 top)
- Ultra-light weight, small & sturdy
- Front COB LED provides lights with up to 400lm
- 100lm top high-power LED lamp
- Strong built-in magnets



STRAIGHT LIGHT 200 LM #SFL201R

\$59⁹⁹

- Front COB LED provides lights with up to 200lm
- 100lm top high-power LED lamp
- Fluorescent reflector
- Light pivots a full 360°
- Powerful magnet
- Flush mounted rotating metal hook



THIN LIGHT 500 LM #ASL501R

\$74⁹⁹

- Front COB LED provides lights with up to 500lm
- 100lm top high-power LED lamp
- Fluorescent reflector
- Light pivots a full 360°
- Powerful magnet
- Flush mounted rotating metal hook



ULTRA THIN UV LED LIGHT R+C COB 200 LM #ASL202RUV

\$74⁹⁹

- Fluorescent reflector
- Light pivots a full 360°
- Powerful magnet
- Flush mounted metal hook on the bottom



STRAIGHT LIGHT 500 LM #SFL501R

\$89⁹⁹

- Top high-power LED lamp
- Flexible 180° bracket with strong magnet
- Fluorescent reflector
- Flush mounted rotating hook
- Intelligent fuel gauge



HEAVY DUTY TRIPOD STAND #ACS301F

\$99⁹⁹

- Adjustable height: 4.4 - 9.8 ft.
- Fits to AUD202H, AUD502H, SPX601H, SPX601C, SPX10K1C and Underhood Light Series
- ALS accessories are heavy-duty construction and adjust to your work needs
- ALS Audio Light Series, Spot Light X Series and Underhood Light Series can attach to these tripods



TRIPOD WHEEL STAND #ACS181W

\$119

- Adjustable height: 4.4 - 9.8 ft.
- Fits to AUD202H, AUD502H, SPX601H, SPX601C, SPX10K1C and Underhood Light Series
- ALS accessories are heavy-duty construction and adjust to your work needs
- ALS Audio Light Series, Spot Light X Series and Underhood Light Series can attach



AUDIO WORK 300/600 LM #AUD601R

\$139

- 3 00/600lm 4/2h operating time (step 1/2)
- 3.7V 3200mAh Li-poly battery IP65
- Fluorescent reflector
- Powerful magnet
- Dust and water resistant



ALUMINUM WORK LIGHT - 2000 LM DC #SPX201R

\$149

- Brightness is adjustable to five (5) levels
- Power bank function
- Fluorescent reflector
- Visual readout of battery life
- Dust and water resistant



ALS

ADVANCED LIGHTING SYSTEMS

UNDER HOOD LIGHT 2000 LM R+C UNDETACHABLE
#UHL201H

\$179

- 1000/2000lm 4/2.5h operating time (Step 1/2)
- 7.4V 5200mAh Li-on battery
- Recorded settings
- Dual fuel system



AUDIO WORK LIGHT 2000 LM R+C
#AUD202H

\$199

- 400/2000lm (5 steps) 2.5/12h operating time
- 7.2V 6000mAh Li-on battery
- Power bank output 5V 1A IP67
- Power bank function
- Fluorescent reflector
- Powerful magnet



ALUMINUM WORK LIGHT 6000 LM AC BLUETOOTH
#SPX601C

\$199

- 1200/6000lm (5 steps)
- Power bank output 5V 1A IP67
- Adjustable Brightness
- Power bank function
- Fluorescent reflector
- Strong built-in magnets
- Fluorescent reflector



UNDER HOOD LIGHT 2000 LM DC UNDETACHABLE
#UHL201R

\$219

- 1000/2000lm 4/2.5h operating time
- Setting is recorded after 5 seconds of activation
- Detachable battery pack for replacing
- Intelligent fuel gauge



UNDER HOOD LIGHT 1000 LM DETACHABLE
#UHL101R

\$229

- Main light: 500/1000lm, Charging Base: 400/800lm 4/2h operating time (Step 1/2)
- 3.6V 5000mAh Li-on detachable battery pack IP5
- Bar extends from 4' to 6.6'
- Light can swivel 360° on the bracket



AUDIO WORK LIGHT 5000 LM R+C
#AUD502H

\$299

- Rechargeable & corded LED audio light
- 1000/5000lm (5 steps), 1.5/7.5h operating time
- 10.8V 6000mAh Li-on battery Power bank
- Fluorescent reflector
- Dust and water resistant



ALUMINUM WORK LIGHT 6000 LM R+C BLUETOOTH
#SPX601H

\$299

- 1200/6000lm (5 steps)
- 1/6h operating time
- 10.8V 6000mAh Li-on battery Power bank
- Adjustable Brightness
- Fluorescent reflector



ALUMINUM WORK LIGHT 10,000 LM AC BLUETOOTH
#SPX10K1C

\$319

- 10000lm corded heavy-duty LED spot
- 2000/10000lm (5 steps)
- Power bank output 5V 1A IP67
- Brightness is adjustable to (5) levels



RECHARGEABLE 250L PENLIGHT + LASER
#2010R

\$54⁹⁹

- 250L of TRUEVIEW™ High Definition Output
- Integrated laser pointer for faster jobsite communication
- Protective rubber bite zone for performing two-handed tasks
- 2M drop rated and IP54 rated: water and dust resistant



RECHARGEABLE 500L CARRY FLASHLIGHT + MAGNET
#2011R

\$54⁹⁹

- 500L of TRUEVIEW™ High Definition Output
- Compact and portable size for Comfortable everyday carry
- Magnetic attachment for Hands-free use and storage



RECHARGEABLE MAGNETIC TASK LIGHT + HEADSTRAP
#2012R

\$54⁹⁹

- 450L TRUEVIEW™ High Definition Output
- Detachable, magnetic task light
- 3 Magnets allow light head to be removed and mounted



USB RECHARGEABLE POCKET FLOOD LIGHT
#2112-21

\$59⁹⁹

- 300 Lumens of TRUEVIEW™ HD Output
- Magnets on Top and Back
- Rotating Clip Functions as Base
- IP54 Rated: Water, Dust, Impact & Chemical Resistant
- Limited Lifetime Warranty



USB RECHARGEABLE ROVER™ PIVOTING FLOOD LIGHT
#2114-21

\$69⁹⁹

- 550 Lumens of TRUEVIEW™ HD output
- Light head pivots 210°
- Magnetic base with carabiner



M12™ ROVER™ SERVICE & REPAIR FLOOD LIGHT
#2367-20

\$69⁹⁹

- Integrated magnetic mounting
- 110 Degrees pivoting light head
- 2.1 Amp USB output
- 700 Lumens



**USB RECHARGEABLE
LOW-PROFILE HEADLAMP**
#2115-21

\$69⁹⁹

- 600 Lumens of TRUEVIEW™ HD Output
- Comfortable for Bare Heads
- Compatible with Hard Hats
- IP54 Rated: Water and Dust Resistant



**USB RECHARGEABLE 800L
COMPACT FLASHLIGHT**
#2160-21

\$69⁹⁹

- 800 Lumens of TRUEVIEW™ HD Output
- The intensity of spotlighting with wide coverage of floodlighting



**USB RECHARGEABLE 1100L
TWIST FOCUS FLASHLIGHT**
#2161-21

\$79⁹⁹

- 1,100 Lumens of TRUEVIEW HD Output
- Precision Twist Focus for Full Control of Beam Size & Intensity



**USB RECHARGEABLE
PIVOTING FLASHLIGHT**
#2113-21

\$79⁹⁹

- 500 Lumens of TRUEVIEW™ HD output
- 110° pivoting light head with spot & flood beam
- Magnetic base for hands-free use



**M12™ ROVER™ MOUNTING
FLOOD LIGHT**
#2364-20

\$79⁹⁹

- As bright as a 250W halogen
- 3 output modes for optimal brightness and runtime
- High Definition output with true color, even beam and natural light



**M18™ ROVER™ F
LOOD LIGHT**
#2361-20

\$89⁹⁹

- 1100 Lumens and up to 1300 lux
- Innovative roll cage design & up to 8 hours of runtime on a single charge
- Up to 30% brighter than corded 250 halogen lights



**M18™ ROVER™ MOUNTING
FLOOD LIGHT**
#2365-20

\$99⁹⁹

- 1500 Lumens of high quality light
- Powerful Magnetic base
- Folding Rotating Light Head
- 2 in. Spring Loaded Clamp
- Impact rating up to 9 ft.



**M18™ SEARCH
LIGHT**
#2354-20

\$99⁹⁹

- 198-Degree head rotation
- 1,250 Lumens with 700 yard beam distance
- 4 output modes: Spot, Flood, Spot/Flood, & Strobe
- Spot mode: 6 hours with M18 XC 5 Ah pack
- Flood mode: 4 hours with
- Spot/Flood Combination mode: 4 hours
- Strobe mode: 5 hours



FREE GOOD WITH PURCHASE



**M12™ ROCKET™ DUAL POWER
TOWER LIGHT**
#2132-20

\$159

- High Mode - 1,400 Lumens
- Low Mode - 700 Lumens
- 31" in length with three side handles to easily transport and store
- 10 hours of light on a single charge with M12™ REDLITHIUM™ XC6.0 battery



FREE GOOD WITH PURCHASE



**M12™ UNDERHOOD
LIGHT KIT**
#2125-21XC

\$279

- Includes 4.0 XC battery
- 1350 Lumens high; 600 Lumens low
- Up to 8 hours run time low; 4 Hours high
- Removable wand



shop supplies



2 LITER PUMP SPRAYER

- Chemical Resistant
- Adjust From A Fine Mist to a Sharp Stream
- Use To Apply Tire Dressing, Engine & Wheel Cleaner, Citrus Degreasers and Mores



#92-722

\$29⁹⁹



1.0L HAND SPRAYER - PUMP & SPRAY EXPERT - FKM /PA (BIO-P)

- Ideal for use with chlorinated brake cleaners and compatible solvents*

#50100

\$59⁹⁹

1.8L VARIO HAND SPRAYER - PUMP & SPRAY EXPERT FKM/PA (BIO-P)

- Ideal for use with chlorinated brake cleaners and compatible solvents*

#50400

\$79⁹⁹



1.0L HAND SPRAYER - PUMP & SPRAY - KPV-FPV/FPE (BIO-P)

- Ideal for use with degreaser*

#50201

\$79⁹⁹

1.8L VARIO HAND SPRAYER - PUMP & SPRAY - KPV-FPV/FPE (BIO-P)

- Ideal for use with degreaser*

#50403

\$99⁹⁹



1.0L HAND SPRAYER PUMP & SPRAY FPV/FPE ACID SPRAYER

- Ideal for use with acid based cleaners, metal etches, aluminum brighteners, etc.*

#50350

\$89⁹⁹



1.0L HAND SPRAYER PUMP & SPRAY - FPV/FPE (BIO-P)

- Ideal for non-chlorinated & chlorinated brake cleaners, most wax & grease removers, pre-conditioners, final wipes, solvents containing M.E.K, xyelene, acetone, toluene, naphtha, etc.*

#50300

\$109

1.8L VARIO HAND SPRAYER PUMP & SPRAY - FPV/FPE (BIO-P)

- Ideal for non-chlorinated & chlorinated brake cleaners, most wax & grease removers, pre-conditioners, final wipes, solvents containing M.E.K, xyelene, acetone, toluene, naphtha, etc.*

#50404

\$119



*Verify Chemical Chart for sprayer compatibility





MANDREL

- Used to convert any die grinder into a cut-off tool using wheels with either 1/4" or 3/8" ID

#12431
(3/8" SHOULDER SCREW)

\$6⁹⁹



BACKING PADS

- Compatible with all twist-to-lock brands of discs, this high quality holder has a rigid rubber pad & twist-to-lock attachment

#13012 (2")

\$7⁹⁹

#13013 (3")

\$9⁹⁹



SURFACE CONDITIONING DISCS

- Designed for all cut-off applications involving steel
- All wheels are double fiberglass reinforced
- Not designed for use on fiberglass or aluminum
- 6 per package

#12757
(3" X 1/16 X 3/8")

\$19⁹⁹

#12758
(3" X 1/32 X 3/8")

\$19⁹⁹



SURFACE CONDITIONING DISCS

- Twist-to-lock feature is great for quick-change & is compatible with all other brands of twist locking style holders
- 25 per box

#620TE
(2" COARSE)

\$21⁹⁹

#622TE
(2" MEDIUM)

\$21⁹⁹

#630TE
(3" COARSE)

\$39⁹⁹

#632TE
(3" MEDIUM)

\$39⁹⁹



SCOTT® SHOP TOWELS

- 55 Shop towels per roll
- Handles the toughest automotive & workshop clean-up challenges with ease
- Excellent at absorbing grease, oil & grime
- Soft, absorbent & strong
- Great for wiping hands & tools

#75130

\$4⁹⁹



SCOTT® SHOP TOWELS

- Ideal for changing oil, refilling fluids & general automotive maintenance
- Super strong—works when wet
- Easily absorbs liquids, oils & grease
- 200 per box



#75190

\$16⁹⁹



SCOTT® RAGS

- Ideal for wiping up spills
- Multi-purpose, soft, absorbent towels that perform like a cloth
- 200 per box



#75260

\$16⁹⁹



WYPALL® L20 WIPERS

- Center-pull roll format
- Multi-ply paper for strength and absorbency
- General purpose wiping
- Use with dispenser #09335

#47758

\$16⁹⁹



HEAVY DUTY HAND CLEANER | CREMES & BOTTLES



| | | |
|-------------------------------------|----------|--------------------------|
| GOJO ORIGINAL CREME 12/14OZ | #1109-12 | \$4⁹⁹ |
| GOJO ORIGINAL CREME PL CTG 6/4.5# | #1115-06 | \$25⁹⁹ |
| GOJO PUMICE CREME/FIP CTG 6/4.5# | #1135-06 | \$29⁹⁹ |
| GOJO LEMON CREME/PUMICE 6/4.5# | #0915-06 | \$30⁹⁹ |
| GOJO CHERRY GEL 2/GAL | #2358-02 | \$30⁹⁹ |
| GOJO N ORIGINAL LTN WITH PUMP 4/GAL | #0945-04 | \$30⁹⁹ |
| GOJO NATURAL ORANGE PUMICE 2/GAL | #0955-02 | \$31⁹⁹ |

GENERAL SOAP



| | | |
|-------------------------------------|----------|--------------------------|
| GOJO GRAY FMX DISP 6/1250ML | #5150-06 | \$24⁹⁹ |
| GOJO LUX FOAM HANDWASH 4/1.25L | #5161-04 | \$26⁹⁹ |
| GOJO LUX FOAM ANTI HANDWASH 4/1.25L | #5162-04 | \$29⁹⁹ |

WIPES



| | | |
|--------------------------------|----------|--------------------------|
| GOJO HD WIPES CANISTER 6/25CT | #6383-06 | \$7⁹⁹ |
| GOJO HD WIPES BKT 6/72CT | #6396-06 | \$18⁹⁹ |
| GOJO FAST WIPES HD 4/130CT BKT | #6298-04 | \$35⁹⁹ |
| GOJO HD WIPES BKT 2/170CT | #6398-02 | \$40⁹⁹ |

HEAVY DUTY HAND CLEANER | DISPENSERS & REFILLS



| | | |
|--------------------------------|----------|--------------------------|
| GOJO PRO TDX GRY DISP 1/2000ML | #7200-01 | \$29⁹⁹ |
| GOJO MULTI GREEN FORM 4/2000ML | #7265-04 | \$34⁹⁹ |
| GOJO PRO TDX GRY DISP 1/5000M | #7500-01 | \$36⁹⁹ |
| GOJO SUPROMAX 4/2000ML | #7272-04 | \$38⁹⁹ |
| GOJO SUPROMAX CHERRY 4/2000M | #7282-04 | \$40⁹⁹ |
| GOJO SUPROMAX 2/5000ML | #7572-02 | \$76⁹⁹ |
| GOJO SUPROMAX CHERRY 2/5000ML | #7582-02 | \$80⁹⁹ |

ask about

OUR  PRODUCTS





PNEUMATIC ROLLING BAR STOOL

- Pneumatic action adjusts seat height from 19" to 24" quickly & easily
- Chrome plated frame & foot rest
- 5 Hooded dual-caster wheels
- Foam padded 13" diameter seat
- 250 lb. capacity

#W85027

\$44⁹⁹

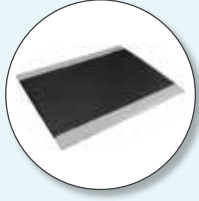

HD VINYL SHOP MAT

- Large non-slip surface
- Tear and abrasion resistant
- Use on tile, wood, marble & treated concrete surfaces
- Anti-fatigue

#W88983

\$49⁹⁹



PNEUMATIC SWIVEL BAR STOOL

- Pneumatic action adjusts seat height from 26"-32" quickly & easily
- 14" diameter synthetic leather foam padded seat with 360° swivel
- Heavy duty steel tubing frame with matte black powder coated finish
- Wide foot stool base comes pre-assembled

#W85011

\$59⁹⁹



SAFETY



SG SAFETY GLASSES BLACK FRAME CLEAR LENS ANTI-FOG

- Lightweight for all day use
- Specially formulated material offers unmatched durability
- Includes lanyard for added convenience
- Wrap around style extends eye protection to the periphery
- 99.9% UV protection

#50001

\$5⁹⁹



SG SAFETY GLASSES BLACK FRAME SMOKE MIRROR LENS ANTI-FOG

- Lightweight for all day use
- Specially formulated material offers unmatched durability
- Includes lanyard for added convenience
- Wrap around style extends eye protection to the periphery
- 99.9% UV protection

#50007

\$5⁹⁹



170-SB CROWN & WINDOW KIT

- Acetate window
- Industrial style sparkguard that can easily be used with more than 40 universal window options

#14955

\$22⁹⁹



ANTHEM+ POLYCARBONATE STYLE FACE SHIELD

- High impact polycarbonate window
- Industrial style sparkguard that can easily be used with more than 40 universal window options

#14953

\$22⁹⁹



MAXVIEW PREMIUM FACE SHIELD

#14200

\$29⁹⁹





PREMIUM DISPOSABLE EARPLUGS

- Contoured bullet shape for easy fit
- Gently & quickly expands to fit ear canal
- Soft, non-irritating PU foam for maximum comfort
- Individually packaged in pairs

#S23410

\$29⁹⁹

PREMIUM REUSABLE EARPLUGS

- 4 flange design ensures optimum ear canal coverage
- Firm push/pull post makes insertion and removal quick and easy
- Made with non-allergenic polymer materials
- Individually packaged in pairs
- One size fits all, 100 pair per box

#S23421

\$109



SAFEGUARD, MAGNETIC CORNER PROTECTION PADS

- Door ding & corner protection
- Magnetic attachment
- Use on lifts, tool chests, shop corners or any edge you need to protect
- Ships as a pair of SAFEGUARD protection pads

#22001020

\$44⁹⁹



FIRE CONTROL ANTI-FOAM FIRE EXTINGUISHER (FC5)

- UL rated 5-B:C
- Suitable for use on Class B (liquids & gases) & Class C (energized electrical equipment) fires
- Discharge range: 4-6'
- Diameter: 3.25"; height: 10.95"
- Pressure gauge provides at-a-glance status
- Supplied with retention strap bracket
- Disposable

#440161MTL

\$31⁹⁹



FIRE CONTROL ANTI-FOAM FIRE EXTINGUISHER (FC340M-VB)

- UL rated 3-A, 40-B:C
- Suitable for use on Class A (trash, wood & paper), Class B (liquids & gases) & Class C (energized electrical equipment) fires
- Discharge range: 12'-18'
- Pressure gauge provides at-a-glance status
- Supplied with retention bracket
- Rechargeable

#466425

\$72⁹⁹





**31-111 GEAR SHIFT KNOB COVER
#31-11**

- 100 per box
- Prevent dirty hand prints & stains
- Elastic band that makes installation quick & easy
- Fits most passenger & light truck applications

\$20⁹⁹



**PRO-TECH SEAT-MATE
#10-001**

- Packed 200 per roll
- Has an unusually high strength to weight ratio
- Trufflene™ formula has built-in stretch to help prevent tool punctures & rips

\$62⁹⁹



**PLASTIC FLOOR-MATE 17" X 21"
#20-000**

- 500 per case
- Plastic material
- Impervious to grease & most chemicals

\$59⁹⁹

**ECONO SEAT GUARD
#10-005**

- Packed 500 per roll
- Has an unusually high strength to weight ratio
- Trufflene™ formula has built-in stretch to help prevent tool punctures & rips

\$72⁹⁹



**STEERING WHEEL COVERS
#30-002**

- 2 sides of elastic
- Excellent protection
- 500 per case

\$62⁹⁹



**ECO-BARRIER RECYCLED
FLOOR-MATE #20-008**

- 500 per box
- Made from 100% recycled fibers of post consumer products, a toxic free process
- Bio-degradable "green" mat

\$62⁹⁹

**TRUCK STEERING WHEEL
COVERS
#30-003**

- 2 sides of elastic
- Excellent protection
- 250 per case

\$83⁹⁹

auto detailing



5 PK BANDED RED SHOP TOWEL #85-762

- 100% Cotton shop towel
- Use for wiping up spills
- Great for cleaning dirt & grime from hands, tools & engine parts

\$3⁹⁹

2PK YELLOW & BLUE GLASS MICROFIBER TOWELS #25-862

- Great for cleaning windows, mirrors, chrome, glass & metals
- Great in the home & for SUVs, trucks, RV & trailers

\$4⁹⁹

#00 STEEL WOOL 16 PAD PACK #25-791

- Repairs burn marks on wood & leather
- Restores aluminum trim
- Cleans old brass & polishes copper

\$5⁹⁹

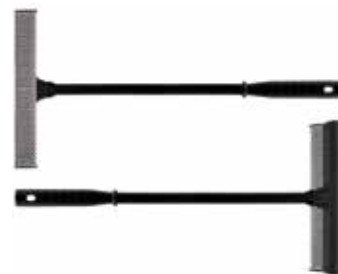

5PK MULTI-COLOR MICROFIBER TOWELS - 14X14 BANDED #25-855

- Multi-color microfiber towels
- Great for cleaning, dusting & detailing
- Use to wax & polish cars, SUV, trucks & boats
- Leaves a lint-free & streak free surface

\$7⁹⁹

HEAVY DUTY WINDOW SQUEEGEE #25-623

- 10" Plastic squeegee head
- 20" Heavy duty plastic handle
- For cleaning & drying windshields & windows

\$7⁹⁹



**24" INDOOR /OUTDOOR
PUSH BROOM**

#92-030

- 3" Black polypropylene bristle
- Use on garages, asphalt, concrete, driveways, basements
- Use on wet or dry surfaces

\$17⁹⁹



**25 PK 100% COTTON RED
SHOP TOWEL - BAG**

#85-766

- 100% Cotton shop towel
- Use for wiping up spills
- Great for cleaning dirt & grime from hands, Tools & engine parts

\$19⁹⁹



**57" HEAVY DUTY
WAREHOUSE BROOM**

#92-412

- Sweeps smooth & rough floors
- Great for the garage, basements & sidewalks
- Sweeps up all kinds of dirt & dust

\$22⁹⁹



**HEAVY DUTY 30" MOSS
RUBBER SQUEEGEE**

#83-304

- 30" Straight moss rubber
- Constructed for tough, industrial usage
- Used to push liquid away on any floor surface

\$24⁹⁹

**USB RECHARGEABLE 800L
COMPACT FLASHLIGHT
#2160-21**

\$69⁹⁹

- 800 Lumens of TRUEVIEW™ HD Output
- The intensity of spotlighting with wide coverage of floodlighting



**USB RECHARGEABLE 1100L
TWIST FOCUS FLASHLIGHT
#2161-21**

\$79⁹⁹

- 1,100 Lumens of TRUEVIEW HD Output
- Precision Twist Focus for Full Control of Beam Size & Intensity



**TEMPERATURE
TOOL
#5811585-1**

\$349

- Gives accurate temperature readings
- Helps in the diagnosis of condensers, evaporators & heaters



**HEATED MOBILE PARTS /
BRAKE WASHER SYSTEM KIT
#14740**

\$2,199

FINANCE:
\$58.32 / month for 60
months

- Less expensive than solvents
- Non-hazardous / non-flammable
- 400 lb. load capacity
- Mobile dolly + locking casters
- Large oversized sink
- Adjustable thermostat 105° to 115°
- Pump capacity @ 300 GPH
- Includes: (1) Unit, (3) 5-gallon containers of OzzyJuice® & (1) filter



SmartWasher®



**1234YF &
HYBRID
#84000000**

\$5,899

FINANCE:
\$136.97 / month for
60 months

- Automatic & Manual
- Integrated Neutronics Refrigerant Identifier
- 8" Color Touch Screen & Built-in WiFi
- 6CFM Vacuum Pump
- Includes: Tank Heater & Thermal Printer



**NITROGEN
PLASTIC
WELDER
#N2-2**

\$5,419

FINANCE:
\$125.83 / month for
60 months

- 4-Cylinder pump
- 15.4 ACFM @ 100 PSI
- No starter required
- 175 Max PSI
- Made in USA



**ROTARY & FORWARD COMBO SET:
LIFT + CHANGER + BALANCER
#146148L10K**

\$13,899

FINANCE:
\$315.51 / month for 60 months



**R146RP AIR SWING
ARM TIRE CHANGER
#RWC246.261RP**

- Air operated
- Helper arm with bead roller
- Plastic mount/demount head
- Hand operated bead breaker
- 3-Year parts
- 1-year labor warranty



Tire not included.

**R155 3D WHEEL
BALANCER + 7-PC
COLLET KIT
#RWB355SB**

- Auto stop on top & indexing
- Laser line guided adhesive weight placement
- 3-Year parts
- 1-year labor warranty



Vehicle not included.

**10,000 LB.
2-POST LIFT
#I10**

- SPOT RITE ARMS position behind the column
- Direct pull cylinders & round adapters & extensions
- 12 months parts & labor warranty

